

**Universität Stuttgart
Fakultät Informatik**

Parallaxis-III User Manual

Thomas Bräunl

Computer Science Report
Bericht Nr. 1996/08 June 1996

<http://www.informatik.uni-stuttgart.de/ipvr/bv/p3>

All Rights Reserved

Copies of this report may be ordered from:

Dekanat der Fakultät Informatik, Universität Stuttgart
Breitwiesenstr. 20-22, D-70565 Stuttgart

phone: +49 (711) 7816-371 fax: +49 (711) 7816-424

Preface

The Parallaxis project started as my Ph.D. project in 1987 at USC, Los Angeles, and continued during my time at the Univ. Stuttgart, Germany. It has gone through several stages of improvements and complete new starts from scratch between the major versions listed below. The idea persisted, however, to formulate a machine independent data-parallel programming language:

version 0 1988 implemented by Thomas Bräunl

version 1 1989 implemented by Ingo Barth (compiler), Frank Sembach (simulator)

version 2 1990 implemented by Barth, Sembach, and Stefan Engelhardt (MasPar)

version 3 1995 implemented by Eduard Kappel, Harald Lampke, Hartmut Keller (all p3c compiler), Jörg Stippa (debugger)

The Parallaxis software, comprising compiler, debugger, numerous parallel application programs, and documentation may be copied over the Internet via "ftp", while some information is available from the p3 web page:

<http://www.informatik.uni-stuttgart.de/ipvr/p3>

<ftp://ftp.informatik.uni-stuttgart.de/ipvr/p3>

Several conference contributions, research reports, and books have been published on Parallaxis, most prominently:

Bräunl: *Parallel Programming*, Prentice-Hall, 1993

Bräunl et al.: *Parallele Bildverarbeitung*, Addison-Wesley, 1995

Stuttgart, June 1996

Thomas Bräunl

Contents

1	Language Definition	5
1.1	Introduction	5
1.2	Specifying Virtual Processors and Connections	6
1.3	Multiple Configurations and Iterative Connections	9
1.4	Data Declaration	10
1.5	Processor Positions	12
1.6	Parallel Execution	14
1.7	Structured Data Exchange	16
1.8	Unstructured Data Exchange	19
1.9	Exchange between Scalar and Vector Data	21
1.10	Reduction	22
1.11	Modules	23
1.12	Input and Output	24
1.13	Control Structures	25
1.14	Relation to Modula-2	26
1.15	Efficiency	27
2	Applications	29
2.1	Basic Applications	29
2.1.1	Cellular Automata	29
2.1.2	Generation of Fractals	30
2.1.3	Sorting	32
2.2	Image Processing	34
2.2.1	Laplace Filter	34
2.2.2	Dithering	35
2.3	Simulation	36
3	Compiler and Debugger	39
3.1	Compiler	39
3.2	Debugger	41
4	Appendix	45
4.1	Data Types	45
4.2	Built-in Functions and Procedures	45
4.3	Graphics Interface	49
4.4	Parallaxis-III Syntax	53
4.5	Literature	58

Chapter 1

Language Definition

Parallaxis is a machine-independent language for data-parallel programming. Sequential Modula-2 is used as the base language. Programming in Parallaxis is done on a level of abstraction with virtual processors and virtual connections, which may be defined by the application programmer.

1.1 Introduction

Parallaxis [Bräunl 89], [Bräunl 91], [Bräunl 93] is based on Modula-2 [Wirth 83], extended by data-parallel concepts. The language is fully machine-independent across SIMD architectures; therefore programs written in Parallaxis run on different SIMD parallel computer systems. For a large number of (single-processor) workstations and personal computers, there is also a Parallaxis simulation system with source level debugging and tools for visualization and timing. A compiler for data-parallel programming of MIMD computer systems in SPMD style (same program, multiple data) is being developed. Parallel programs with small data sets can be developed, tested and debugged with this simulation system. Then, Parallaxis compilers can be used to generate parallel code for the MasPar MP-1 / MP-2 or the Connection Machine CM-2. The simulation environment allows both the study of data parallel fundamentals on simple computer systems and the development of parallel programs which can later be executed on expensive parallel computer systems. The programming environment for Parallaxis is available as public domain software.

We had two major goals in developing a new parallel programming language:

1. We believe that 'structured programming' has a number of advantages in developing sequential *and* parallel software, as well as for learning programming concepts in general. Therefore, we chose Modula-2 as base language and not C like many other approaches.
2. Almost all commercial SIMD programming languages are machine-dependent, since they have been specifically designed for a single hardware platform to achieve maximum performance. Therefore, one may not easily port a program from one SIMD system to another. To avoid this problem, we designed Parallaxis to be completely machine-independent. This refers to SIMD architectures only, for switching from SIMD to MIMD will almost always require to change the *algorithm* of your program, in order to keep it efficient.

The central point of Parallaxis is programming on a level of abstraction with virtual PEs and virtual connections. In addition to the algorithmic description, every program includes a semi-dynamic connection declaration in functional form. This means that the

desired PE network topology is specified in advance for each program (or for each procedure) and can be addressed in the algorithmic section with symbolic names (instead of complicated arithmetic index or pointer expressions). However, for completeness, also full-dynamic data exchange operations may be performed.

The following describes the latest version of the language, *Parallaxis-III*, which is not fully compatible to older versions of the language.

1.2 Specifying Virtual Processors and Connections

One or several ‘virtual machines’ consisting of processors and a connection network may be defined for every Parallaxis program. This is done in two simple steps. First, the keyword `CONFIGURATION` is used to specify the number of PEs and their arrangement in analogy to an array declaration. However, at this point, no specification has been made as to the connection structure between the PEs. This follows by specifying mapping relations, introduced by the keyword `CONNECTION` (this second step may be omitted if no connections are required). Every connection has a symbolic name and defines a mapping from a PE (*any* PE) to the corresponding neighbor PE. The specification of this *relative* neighbor is accomplished by providing an arithmetic expression for the index of the destination PE. Data exchanges can now be carried out using these symbolic connection names in the parallel program.

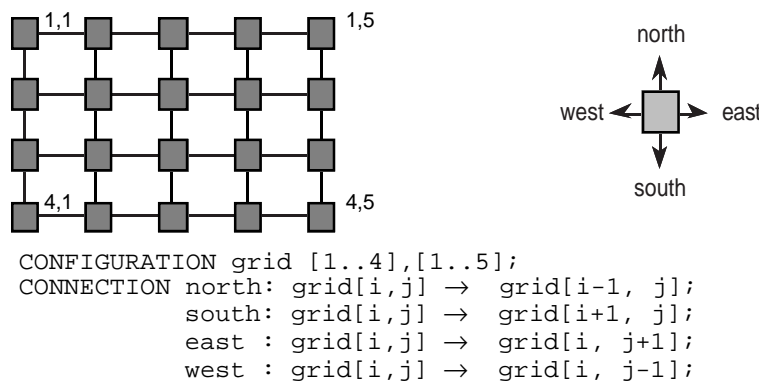

Figure 1.1: Two-dimensional grid topology with representative PE

Figure 1.1 shows a PE arrangement as a two-dimensional grid structure in a simple Parallaxis example. The `CONFIGURATION` declaration provides 4×5 virtual processors, which are virtually connected to one another in the following `CONNECTION` declaration. In Figure 1.1, PE no. [1,1] is in the upper left corner; however, you may also choose to put the ‘origin’ in the lower left corner – it does not matter as long as you use it consistently in your program. Since homogeneous connection structures or topologies are easy to declare, four connection declarations are sufficient to construct a grid of any size. One connection is defined for each cardinal direction. The connection to the north, for example, decrements the first index. Some connections from the border PEs lead ‘nowhere’, which means that these connections do not exist, and will not participate in any data exchange operation.

In case one prefers a wrapped-around grid (torus) instead of an open grid for some application, this can be easily accomplished by using the modulo-operator (remainder). Identifiers h and w denote constants:

```
CONFIGURATION torus [0..h-1],[0..w-1];
CONNECTION north: torus[i,j] → torus[(i-1) MOD h, j];
          south: torus[i,j] → torus[(i+1) MOD h, j];
          east : torus[i,j] → torus[i, (j+1) MOD w];
          west : torus[i,j] → torus[i, (j-1) MOD w];
```

There is a list of extensions to this simple process of defining virtual machine structures: Several destination expressions may be specified after the arrow symbol, separated by commata. Connections may be *parameterized*, as with the hypercube in Figure 1.2. With these, it is possible to perform a data exchange in a *computed* direction. For the definition of the binary tree network, also in Figure 1.2, *bi-directional* connections (' \leftrightarrow ' or ' \leftarrow ' in ASCII notation) have been used instead of *uni-directional* connections (' \rightarrow ' or ' \leftarrow '). A bi-directional connection is an abbreviation for two uni-directional connections and, therefore, requires a second connection name on the right hand side of the connection.

Binary Tree

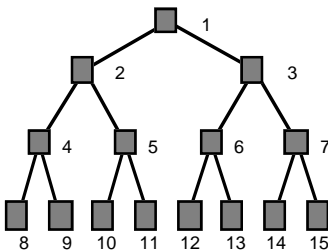

```
CONFIGURATION tree [1..15];
CONNECTION
  lchild: tree[i] ↔ tree[2*i] :parent;
  rchild: tree[i] ↔ tree[2*i+1] :parent;
```

an alternative specification without distinguishing between left and right children is:

```
CONFIGURATION tree [1..15];
CONNECTION child: tree[i] → tree[2*i],
              tree[2*i+1];
```

Hypercube

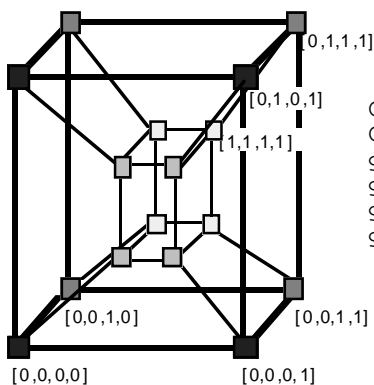

```
CONFIGURATION hyper [0..1],[0..1],[0..1],[0..1];
CONNECTION
  go[1]: hyper[i,j,k,l] → hyper[(i+1)MOD 2, j,k,l];
  go[2]: hyper[i,j,k,l] → hyper[i, (j+1)MOD 2, k,l];
  go[3]: hyper[i,j,k,l] → hyper[i,j, (k+1)MOD 2, l];
  go[4]: hyper[i,j,k,l] → hyper[i,j,k, (l+1)MOD 2];
```

Figure 1.2: Tree and hypercube topology

So-called 'compound connections' may be used to have a case distinction inside a connection. The following example connects local pairs of PEs:

A case distinction is made for the `next` connection. If the PE-number is odd, a connection to the right neighbor is established, while if it is even, a connection to the left neighbor is established. Using compound connections, arbitrary connection

```

CONFIGURATION list [1..8];
CONNECTION next: list[i] → {ODD (i)} list[i+1],
                           {EVEN(i)} list[i-1];

```



Figure 1.3: Compound connections

structures, even with irregularities, may be defined. If several parts of a compound connection evaluate to `TRUE` for a particular PE, then for this PE all of these connections are defined (one-to-many or 1: n connection).

The connection structures as defined by the `CONNECTION` declaration do not have to be 1:1 (one-to-one) connections. For 1: n connections, an implicit broadcast is executed. In the following example, the first element of each row is connected to all elements in this row.

```

CONFIGURATION grid [1..100],[1..100];
CONNECTION one2many: grid[i,1] → grid[i,1..100];

```

If a one-to-many connection is to be established to all PEs of a dimension, the range may be substituted by an asterisk `*`. So the following is equivalent to the previous example.

```

CONFIGURATION grid [1..100],[1..100];
CONNECTION one2many: grid[i,1] → grid[i,*];

```

However, for n :1 (many-to-one) connections (and the general m : n connections, many-to-many) one must ensure that only a single value arrives at any PE's entry port. Therefore, each data exchange operation may include a vector reduction, as will be discussed later. In the following example, all elements of a row are connected to the first element in their column.

```

CONFIGURATION grid [1..3],[1..5];
CONNECTION many2one: grid[i,j] → grid[i,1];

```

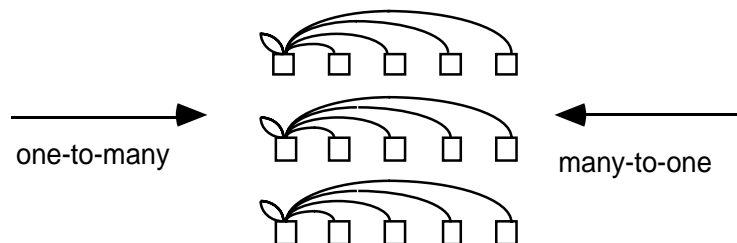

Figure 1.4: Multiple connections

1.3 Multiple Configurations and Iterative Connections

In addition to the constructs shown so far, the definition of multiple topologies in a program is possible. These may be defined independently of each other on separate groups of PEs – in which case the topologies may have different vector data structures. Or the topologies can be defined as ‘different views’ of the same set of PEs with identical data structure. Furthermore, local topologies may be defined in procedures, thus allowing semi-dynamic connection structures.

Different configuration definitions denote different sets of PEs. For example, the following declaration defines two *distinct sets* of PEs:

```
CONFIGURATION grid [1..200],[1..50];
                tree [1..10000];
```

On the other hand, configurations may be defined as a *different view* of the *same set* of PEs. In this case, the numbers of PEs have to be identical. In that case, each PE a

```
CONFIGURATION grid [1..200],[1..50];
                tree [1..10000] = grid;
```

Connections may be specified between multiple configurations, whether they belong to the same or distinct sets of PEs:

```
CONFIGURATION grid [0..199],[0..49];
                tree [1..10000];
CONNECTION mix: grid[i,j] -> tree[i*50 + j];
```

However, a connection may only link PEs within the same or two different configurations. A connection between three or more configurations is not allowed, and a connection linking PEs within one configuration *and* PEs to another configuration (by the same connection name) is not allowed.

Configurations only come to life, when they are used for the declaration of a vector variable, which is later used in a computation. A vector variable based on a configuration with multiple views can make use of all connection structures defined for any of the views. Such a variable is also assignment compatible to a variable of the same type but of a different view.

An extension to the definition of connections is the use of iterative connection functions, as exemplified by the following alternative definition for a hypercube network of arbitrary size (the exponentiation function is denoted by ‘**’, n is a constant):

```
CONFIGURATION hyper [0..(2**n-1)];
CONNECTION FOR k := 0 TO n-1 DO
    dir[k]: hyper[i] ↔ {EVEN(i DIV 2**k)}
                    hyper[i + 2**k] :dir[k];
END;
```

If n equals 10, there are 1,024 PEs defined together with ten bi-directional connections. Expression `EVEN(i DIV 2**k)` tests, whether the k -th bit of i equals 0.

A large program may be split into several modules, which are compiled separately. So, e.g. for a module containing library functions, it may be desirable *not* to specify the size of a configuration. When writing routines for image processing, the size of the

grid structure should be left unspecified and will be defined later by the module importing these routines. An open configuration is indicated by using an asterisk '*' instead of a value range. The configuration size may be determined dynamically at run time, e.g. by passing a parameter that is subsequently used as an upper bound in the configuration declaration.

```
DEFINITION MODULE Open;
CONFIGURATION grid[*],[*];
CONNECTION left: grid[i,j] <-> grid[i ,j-1] :right;
           up  : grid[i,j] <-> grid[i+1,j ] :down;
PROCEDURE sum_3x3(input: grid OF INTEGER): grid OF INTEGER;
END Open.
```

```
MODULE Main;
FROM Open IMPORT grid, sum_3x3;
CONFIGURATION my_grid = grid[1..10],[1..10];
VAR a,b: my_grid OF INTEGER;
BEGIN
  a := 1;
  b := sum_3x3(a);
  WriteInt(b,5);
END Main.
```

Open configurations are needed when a procedure is to work on a vector of unspecified size, but has to make use of connections for data exchange or position data (DIM, see section on processor positions). If connections and position data are not required in a procedure, which is to be used for different configurations (different size or arbitrary configuration), then the simpler concept of generic vector parameters may be used (VECTOR, see section on data declaration).

1.4 Data Declaration

Parallaxis differentiates between scalar and vector variables in data declarations as well as in procedure parameters and results. Scalar data is placed on the control processor, while vectors are distributed component-wise among the virtual PEs (in Figure 1.5 configurations are not connected).

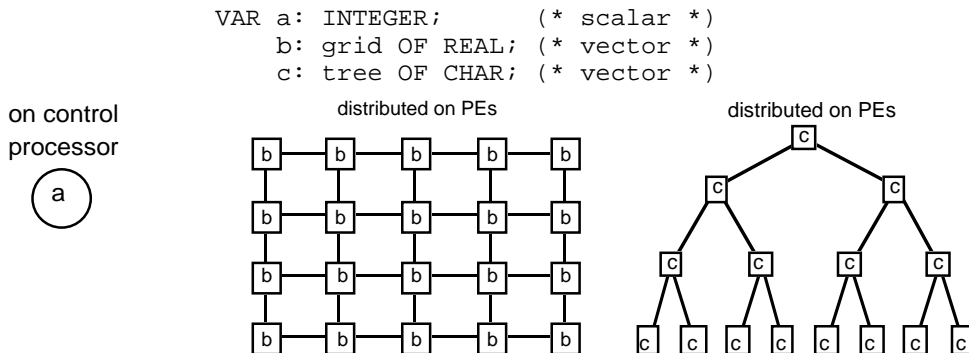

Figure 1.5: Allocation of scalar and vector data

configurations with different numbers of PEs, the name of a configuration is used for specifying the vector type of a variable.

There is, of course a fundamental difference between declaring an array of vectors and declaring a vector of arrays, as exemplified in Figure 1.6. However, both indexed expressions `x[1]` and `y[1]` refer to a data structure of the same type "grid OF INTEGER".

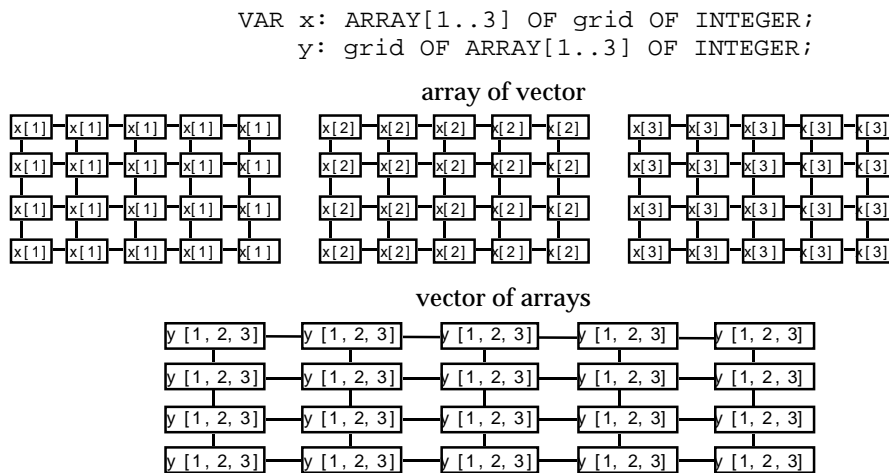

Figure 1.6: Array of vectors and vector of arrays

Unfortunately, this declaration semantics has some unpleasant effect for procedure arguments. Imagine, e.g. writing a function `factorial`, for computing the factorial value for an argument of type `INTEGER`. Now, a `factorial` function would have to be declared for scalar arguments, and for *every configuration defined* in a program. Since there is no way of knowing them in advance, it would be impossible to write general library routines. To remedy this situation, parameters and variable declarations inside such a procedure may use the keyword `VECTOR` instead of a particular configuration name. This indicates that a parameter will be used in a parallel computation, without specifying a particular configuration (this results in a *generic procedure*). All parameters declared as generic vectors or variables in such a procedure have to belong to the *same* configuration. Since no particular configuration has been specified, no data exchange may be performed in such a procedure.

```

PROCEDURE s_factorial(a: INTEGER): INTEGER;
VAR b: INTEGER;
    (* scalar *)
...
END s_factorial;

PROCEDURE v_factorial(a: VECTOR OF INTEGER): VECTOR OF INTEGER;
VAR b: VECTOR OF INTEGER;
    (* any vector *)
...
END v_factorial;

```

It is possible that several procedure parameters use the "open vector" or the "open configuration" construct for **possibly different** configurations. In this case, a local variable declaration with the method used above is not unique. Therefore, the name

of the "open vector" or open configuration parameter may follow the keyword `VECTOR` or the open configuration name in the type specification.

```

PROCEDURE vec(a: VECTOR OF INTEGER; b: VECTOR OF INTEGER);
VAR x: VECTOR a OF INTEGER; (* vector type corresponding to a *)
    y: VECTOR b OF INTEGER; (* vector type corresponding to b *)
    ...
END vec;

CONFIGURATION grid[*],[*];

PROCEDURE open(a: grid OF REAL; b: grid OF REAL);
VAR x: grid b OF REAL; (* vector type corresponding to b *)
    ...
END open;

```

1.5 Processor Positions

There are two ways to determine a PE's current position. The first is by using the (vector-valued) standard function `ID`, which returns the virtual processor position as a single number in row-major ordering (or 'highest-dimension-major' for more than two dimensions):

```

CONFIGURATION grid [1..4],[-2..+2];
...
VAR x: grid OF INTEGER;
...
x := ID(grid);

```

This results in each component of `x` being assigned the number of its virtual PE, *always* starting with '1' (independent of the configuration range and number of dimensions):

$$\text{ID}(\text{grid}) = \begin{bmatrix} 1 & 2 & 3 & 4 & 5 \\ 6 & 7 & 8 & 9 & 10 \\ 11 & 12 & 13 & 14 & 15 \\ 16 & 17 & 18 & 19 & 20 \end{bmatrix}$$

The second way of determining the position of a virtual PE, now with respect to its configuration declaration, is to use the standard function `DIM`. This function takes the configuration name and the number of the dimension as arguments and returns the position of a PE within this dimension. Dimensions are numbered from right to left, that is, the highest dimension is at the leftmost position.

The position values returned by function `DIM` depend on the ranges of the configuration definition. The `DIM` function will return exactly this range of values as position data. In the following, position data for rows and columns of the grid example above are shown:

$$\text{DIM}(\text{grid}, 2) = \begin{bmatrix} 1 & 1 & 1 & 1 & 1 \\ 2 & 2 & 2 & 2 & 2 \\ 3 & 3 & 3 & 3 & 3 \\ 4 & 4 & 4 & 4 & 4 \end{bmatrix} \quad \text{DIM}(\text{grid}, 1) = \begin{bmatrix} -2 & -1 & 0 & +1 & +2 \\ -2 & -1 & 0 & +1 & +2 \\ -2 & -1 & 0 & +1 & +2 \\ -2 & -1 & 0 & +1 & +2 \end{bmatrix}$$

Functions, `ID` and `DIM`, as well as the following functions, do not depend on any PE connection. Further functions working on configuration data are shown below. These functions take either configurations or vector variables as arguments.

<code>LEN(grid)</code>	= 20	returns the total number of PEs in a configuration
<code>LEN(grid,1)</code>	= 5	returns the size of a dimension (here dim. 1)
<code>LEN(grid,2)</code>	= 4	returns the size of a dimension (here dim. 2)
<code>RANK(grid)</code>	= 2	returns the number of dimensions
<code>LOWER(grid,1)</code>	= -2	returns the lower bound of a dim. (here dim. 1)
<code>UPPER(grid,1)</code>	= 2	returns the upper bound of a dim. (here dim. 1)

A function and a procedure are provided to transfer `ID` values into `DIM` values and vice versa. An array is used for `DIM` values. Both routines may be used with scalar or vector parameters. These routines are especially useful for converting `ID` and `DIM` values of multiple configurations.

```
VAR dims: ARRAY[1..2] OF INTEGER;
    s    : INTEGER;
...
dims[1] := 1;
dims[2] := 2;
s := DIM2ID(grid,dims);  s becomes 9 (referring to grid definition above)
...
ID2DIM(grid,12,dims);   dims[1] becomes -1
                        dims[2] becomes +3
```

An individual PE may be selected by using an `IF`-selection involving parallel position data like `ID` and `DIM`. However, supplying the position values directly for a vector is also possible and gives a simpler way of selecting PEs. A single PE may be selected using a component expression with scalar arguments after the identifier of a vector variable:

```
VAR x  : grid OF INTEGER;  (* 2-dim. *)
    s,t: INTEGER;         (* scalar *)
...
s := x <<12>>;           get the value of the PE with ID 12
x <<12>> := s;           set the value of the PE with ID 12

s := x <<:3,t+1:>>;     get value of the PE in row 3 and column t+1,
                        according to CONFIGURATION ranges specified

x <<:t,1:>> := s;       set the value of the PE in row t and column 1
```

1.6 Parallel Execution

Parallel execution is implicit in Parallaxis-III, depending on the declaration of variables involved in a statement or expression. PE-selection (determining which PEs will be active during a certain statement) is also implicit. Any selection or iteration instruction (IF, FOR, WHILE, REPEAT, CASE, LOOP) with a vector argument may be used. Figure 1.7 shows the data-parallel execution of a statement on a selected group of PEs.

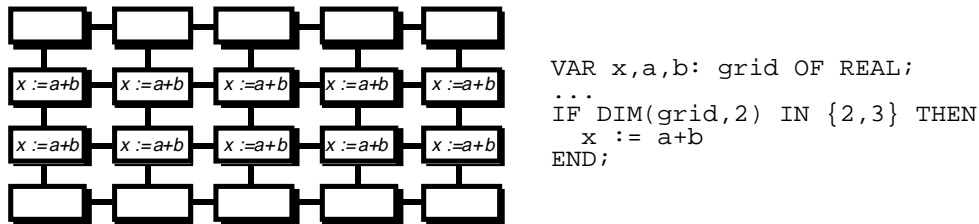

Figure 1.7: Data parallel instruction

So whenever a selection is performed, e.g. by an IF statement with vector condition, only those PEs are active during execution of the THEN branch, whose local condition evaluates to TRUE. A THEN branch or an ELSE branch will only be executed if the condition (or its negation, respectively) will be satisfied by at least one PE. Primarily, this has an effect on any scalar statements that may be in such a branch, since in this case they will be skipped. In the general case, when the condition evaluates to TRUE for some PEs, but evaluates to FALSE for some other PEs, then both THEN branch and ELSE branch will be executed subsequently (first THEN, afterwards ELSE) with the appropriate group of PEs being active (this also holds for any scalar statements that may be contained in these branches). If vector IF statements are nested, then in one of the inner branches only a subset of the PEs of the corresponding outer branch is active.

```

VAR x: grid OF INTEGER;
...
IF x>5 THEN x := x - 3
  ELSE x := 2 * x
END;

```

PE-ID:	1	2	3	4	5	
initial values of x:	10	4	17	1	20	
starting then-branch:	10	-	17	-	20	('-' means inactive)
after then-branch:	7	-	14	-	17	
starting else-branch:	-	4	-	1	-	
after else-branch:	-	8	-	2	-	
selection done						
after if-selection:	7	8	14	2	17	

The possibly subsequent execution of THEN- und ELSE-branches may lead to unexpected side effect, which are shown in the following sample program:

```
VAR x: grid OF INTEGER;
    s: INTEGER, (* scalar *)
...
IF x>5 THEN x := x - 3; INC(s);
           ELSE x := 2 * x; INC(s);
END;
```

initial values of s:	1
after <i>then</i> -branch:	2
after <i>else</i> -branch / <i>if</i> :	3

When entering a loop with vector condition (e.g. WHILE loop), only those PEs are active which satisfy the condition. In subsequent iterations of this loop, the number of PEs is *always decreasing*. The loop iterates until no PE is left to satisfy the loop condition (see the following example).

```
VAR x: grid OF INTEGER;
...
WHILE x>5 DO
  x := x DIV 2;
END;
```

<i>PE-ID:</i>	1	2	3	4	5	
initial values of x:	10	4	17	1	20	
starting 1st iteration:	10	-	17	-	20	('-' means inactive)
after 1st iteration:	5	-	8	-	10	
starting 2nd iteration:	-	-	8	-	10	
after 2nd iteration:	-	-	4	-	5	
starting 3rd iteration:	-	-	-	-	-	
<i>loop terminates</i>						
after loop:	5	4	4	1	5	

Other control structures, known from sequential Modula-2 may be used as well in vector context. The CASE-selection can be treated as a nested chain of IF-THEN-ELSIF-selections, while FOR- and REPEAT-loops can be regarded as modifications of a WHILE-loop. The parallel LOOP-EXIT construct differs from its sequential counterpart, for it has to specify the name of the selected configuration, e.g.:

```
LOOP OF grid DO
...
  IF x>0 THEN EXIT END;
...
END; (* loop *)
```

In case one would like to perform an operation on *all PEs* inside a nested selection or loop, the `ALL` block may be used to re-activate all PEs of a configuration.

```

IF x>0
  THEN ... (* only grid PEs are active, which satisfy condition *)
    ALL grid DO
      ... (* all grid PEs are active, regardless of condition *)
    END
  ELSE ... (* only grid PEs are active, which do not satisfy cond. *)
END;

```

1.7 Structured Data Exchange

Data exchanges between processors can be accomplished with simple symbolic names, thanks to the network declaration described earlier. Data exchange of a local vector variable between all or just a group of PEs can be invoked by calling system function `MOVE` with the name of a previously defined connection. Only active PEs participate in a data exchange operation. Figure 1.8 shows an example of a data exchange in the grid structure defined in section 1.2. The expression returns vector variable `x` shifted one step (one PE) to the east.

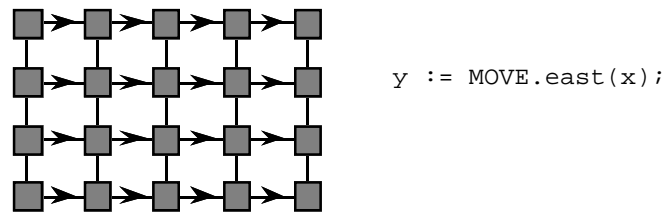

Figure 1.8: Synchronous data exchange

For the data exchange operation shown above, sender-PE *and* receiver-PE of a data exchange have to be active. For the operations `SEND` and `RECEIVE` shown below, it is sufficient for *only* the sender (or *only* the receiver, respectively) to be active. These operations are especially needed for the data exchange between different topologies, since due to the SIMD model only one PE structure can be active at a time. Unlike the other data exchange operations, `SEND` is a procedure (not returning a value) and therefore takes two arguments, first the expression to be sent, and second the variable to receive the expression.

```

SEND.east(4*x, y);
y := RECEIVE.north(x);

```

The following comparison shows the differences in data exchange operations by using a simple list topology. In figures, an arrow represents data transport, while a white space marks an inactive PE. Let us assume for the context of the following data exchange operations that all PEs are active but one (e.g. the data exchange might occur inside an `IF`-selection, which deactivated one of the PEs).

```

CONFIGURATION list[1..max];
CONNECTION right: list[i] -> list[i+1];
VAR x,y: list OF INTEGER;

```

- a) Only the sender has to be active.

All active PEs, which have a successor, send data.

```
SEND.right(x,y);
```



active inactive active active

Example: before after
 x: 1 2 3 4 x: 1 2 3 4
 y: 0 0 0 0 y: 0 1 0 3

- b) Only the receiver has to be active.

All active PEs, which have a predecessor, receive data.

```
y := RECEIVE.right(x);
```

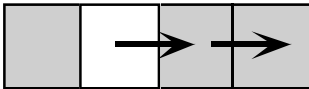

Example: before after
 x: 1 2 3 4 x: 1 2 3 4
 y: 0 0 0 0 y: 1 0 2 3

- c) Both sender and receiver have to be active.

All active PEs, which have an active successor, send data.

```
y := MOVE.right(x);
```



Example: before after
 x: 1 2 3 4 x: 1 2 3 4
 y: 0 0 0 0 y: 1 0 3 3

- d) Neither sender nor receiver have to be active.

All PEs, which have a successor, send data – independent of their activation status.

This version does not seem to make much sense, so it is not included in Parallaxis (use ALL plus data exchange statement instead).

Please note:

- SEND has to be a procedure for it writes to inactive PEs, while MOVE and RECEIVE are functions returning vector data.
- All data exchange operations shift data in the direction indicated by the connection identifier (here: right). This also holds for the RECEIVE function, so it does *not* have the semantics "receive *from* a direction" (e.g. RECEIVE.right shifts data to the right, not to the left).

Additional data exchange modifiers may be specified for some of the data exchange operations. One is for multiple data movement steps and one is for an implicit reduction; both are separated by colons.

A data exchange operation may be executed several steps (*subsequently*) in a specified direction for the `SEND` statement. After each step, all PEs that received data will be active, sending data in the next step. In case one data element is sent to multiple PEs, then all of these will be active in the next step. This feature is extremely useful when exchanging data over a tree structure.

```
VAR x,y: list OF INTEGER;
...
SEND.right:2 (x,y);           move data two steps to the east
```

Example: (only PEs 1 and 2 are active, PEs 3 and 4 are inactive)

	before	copy expr.	1st step	2nd step	assignment
x:	1 2 3 4	—	—	—	1 2 3 4
intermediate variable:	—	1 2 3 4	1 1 2 4	1 1 1 2	—
y:	0 0 0 0	—	—	—	0 0 1 2

A problem might occur, if several PEs are connected to a single one (many-to-one connection). There are two possibilities to avoid an undetermined result (any of the incoming data values could be chosen). One can either deactivate unwanted PEs (`IF-selection`), so they cannot participate in a data exchange, or one can use a reduction function with the data exchange.

For example, in the tree network shown before, one might want to send only the left children's data to the parents and discard the right children's data:

```
VAR u,v,w: tree OF INTEGER;
...
v := u;           initializes all components of v
IF EVEN(ID(tree)) THEN
  SEND.parent (u,v) moves only the left children's data up the tree
END;
```

Now assume, one does *not* want to discard information, but one would like to add the left and right child's data before sending to the parent node:

```
w := MOVE.parent:#SUM (u); moves data from both children to the
                             parent, resolving multiple arriving data
                             by adding
```

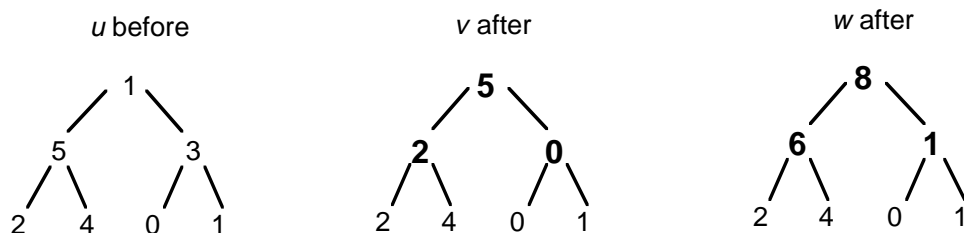

Figure 1.9: Move without and with reduction

There is a number of system-defined operations to do this *reduction*, and also user-defined operations may be specified (see section on reduction below).

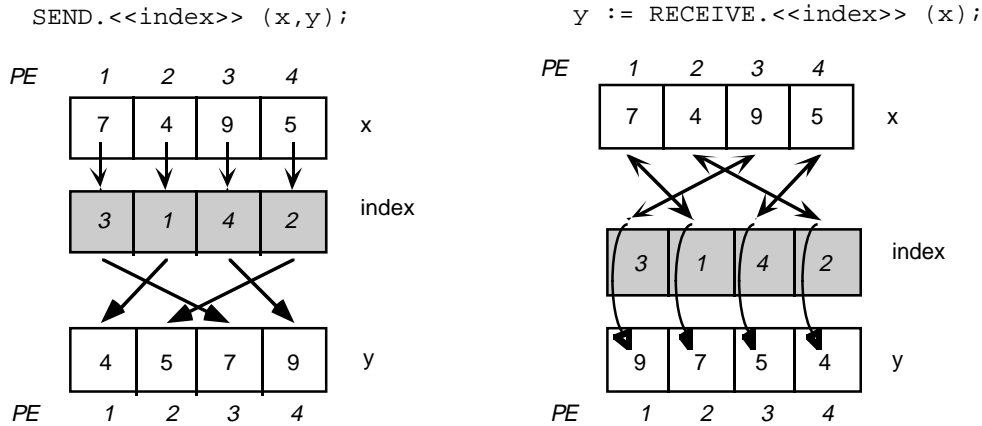

Figure 1.10: Unstructured data exchange

Besides using a single index, referring to the `ID` position of PEs, several indices referring to `DIM` positions may be used as well. Also, this kind of data exchange does not have to be a one-to-one correspondance. If several indices refer to the same PE position, for `RECEIVE` (one-to-many) this results in a broadcast, while for `SEND` (many-to-one) an arbitrary component is selected – unless a reduction operation (see section on reduction) is specified for resolving collisions.

```
CONFIGURATION grid [1..2],[1..3];
VAR x,y, index,d1,d2: grid OF INTEGER;
...
```

SEND.<:d2,d1:> (x,y); sends data from all components of x to a destination, determined in the first dimension by d1, and in the second dimension by d2

$$\text{E.g. } x = \begin{bmatrix} 7 & 3 & 5 \\ 4 & 2 & 3 \end{bmatrix} \quad d2 = \begin{bmatrix} 1 & 2 & 1 \\ 2 & 1 & 2 \end{bmatrix} \quad d1 = \begin{bmatrix} 3 & 2 & 1 \\ 3 & 2 & 1 \end{bmatrix} \quad \text{then } y = \begin{bmatrix} 5 & 2 & 7 \\ 3 & 3 & 4 \end{bmatrix}$$

SEND.<<index>>:#SUM (x,y); in case the expression `index` does not provide a 1:1 permutation, it may be desirable to perform a reduction of multiple values arriving in one port, in order to avoid the assignment of an arbitrary one of these; positions not indexed get the sender's original elements

$$\text{E.g. } x = \begin{bmatrix} 7 & 3 & 5 \\ 4 & 2 & 3 \end{bmatrix} \quad \text{index} = \begin{bmatrix} 1 & 3 & 2 \\ 6 & 6 & 6 \end{bmatrix} \quad \text{then } y = \begin{bmatrix} 7 & 5 & 3 \\ 4 & 2 & 9 \end{bmatrix}$$

Two kinds of abbreviations are possible for data exchanges with index expressions:

- a) If the positions in one dimension are to remain unchanged, one should use the expression `DIM(conf_name, dim_no)` as an index. This may be abbreviated with the symbol `*`.

```
SEND.<:DIM(grid,2),d1:> (x,y);           is equivalent to:
SEND.<:*,d1:> (x,y);
```

- b) If a dimension is to be collapsed, a many-to-one data exchange may be used in combination with a reduction. For example, a matrix may be collapsed to a single column by reducing all of its rows. This can be done by sending all row elements to the first element in the same row with a reduction operation. This may be abbreviated by using a reduction operation (e.g. `#SUM`) instead of an index expression. Only a *single* reduction may be specified in an index expression.

```
SEND.<:d2,1:> :#SUM (x,y);           is equivalent to the general:
SEND.<:d2,LOWER(grid,1):> :#SUM (x,y); is equivalent to:
SEND.<:d2,#SUM:> (x,y);           dimension 1 is reduced by addition (rows
                                  accumulate data in their first positions)
                                  with permutation in dimension 2
                                  according to d2
```

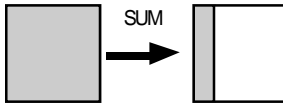

$$\text{E.g. } x = \begin{bmatrix} 7 & 3 & 5 \\ 4 & 2 & 3 \end{bmatrix} \quad d2 = \begin{bmatrix} 1 & 1 & 1 \\ 2 & 2 & 2 \end{bmatrix} \quad \text{then} \quad y = \begin{bmatrix} 15 & 3 & 5 \\ 9 & 2 & 3 \end{bmatrix}$$

1.9 Exchange between Scalar and Vector Data

Communication between the control processor and the parallel PEs also requires additional language constructs or in some cases an adapted semantics. Transferring a scalar field into a parallel vector is invoked with procedure `LOAD`, while transferring data back into a scalar field from a vector is accomplished with `STORE` (Figure 1.8). Only active PEs participate in this sequential data exchange. `STORE` with inactive PEs does not result in gaps in the scalar array, but data elements are stored subsequently. `LOAD` with inactive PEs assigns the next array value to the next active PE, no scalar array elements will be skipped. Surplus elements will not be used, too few elements leave the corresponding array elements (or vector components, respectively) unchanged. The execution of this operation usually requires n time steps for a data array with n elements. A scalar integer variable may be specified as an optional third parameter for `LOAD` and `STORE`, which limits the number of data items transferred and also receives the number of data items actually transferred after the operation.

```

CONFIGURATION list[1..n];
VAR  s: ARRAY[1..n] OF INTEGER;
      t: INTEGER;
      v: list OF INTEGER;
...
LOAD (v, s); (* from scalar to vector *)
STORE(v, s); (* from vector to scalar *)
STORE(v, s, t); (* here, t becomes num. active PEs *)
(* require n steps each *)

```

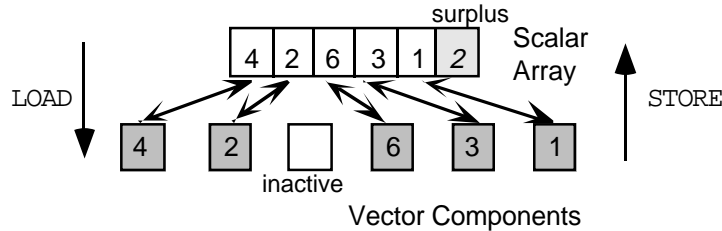

```

v := t; (* requires 1 step *)

```

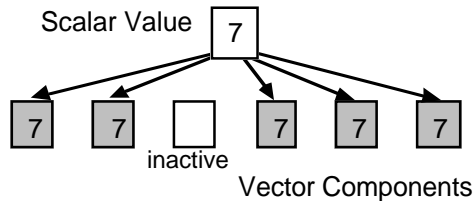

Figure 1.11: Data exchanges between PEs and control processor

Figure 1.8 (bottom) also shows an assignment in which a (constant or variable) scalar data value is copied into all or a group of PEs. Every component of the vector contains the same value as the scalar. This operation is implemented by an implicit *broadcast* and therefore requires only a single time step.

1.10 Reduction

The reduction of a vector to a scalar is another important operation. The `REDUCE` operation handles this task in conjunction with a system-defined or user-defined (programmable) reduction operation (see Figure 1.12). System-defined operators are:

```
SUM, PRODUCT, MAX, MIN, AND, OR, FIRST, LAST
```

The operators `FIRST` and `LAST` return the value of the first or last currently active PE, respectively, according to its identification number (ID).

Example: `s := REDUCE.FIRST(x)` is identical to:

```

pos := REDUCE.MIN(ID(x));
s := x<<pos>>;

```

All other reduction operators' functions can easily be deduced from their names. The execution of a reduction operation requires about $\log_2 n$ time steps for a vector with n active components. However, this time estimation depends on the physical connection structure of the PEs.

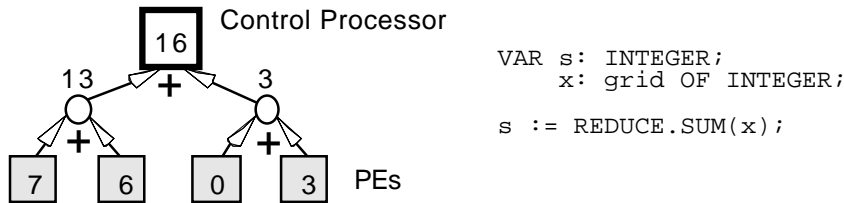

Figure 1.12: Vector reduction in Parallaxis

The following example shows the use of the `REDUCE` operation with a user-defined function. Such a function has to have two vector input parameters and has to return a vector value of the same type. Note that the reduction function implemented by the user should be associative and commutative, or unpredictable results may occur, e.g. $(1 - 2) - 3 \neq 1 - (2 - 3)$.

```

VAR v: grid OF BOOLEAN;
    s: BOOLEAN;

...
PROCEDURE xor (a,b: VECTOR OF BOOLEAN): VECTOR OF BOOLEAN;
BEGIN
    RETURN(a <> b);
END xor;

...
s := REDUCE.xor(v);

```

There are a few places, where substituting a scalar constant in lieu of a vector variable makes sense, but lacks information about the configuration to be used. Consider the problem of counting the number of active PEs for some configuration. Instead of using a vector variable, the constant 1 can be used for each PE, however, it has to be type cast to the appropriate configuration:

```
s := REDUCE.SUM( grid(1) );
```

1.11 Modules

In Parallaxis, like in Modula-2, each module consists of two files: a definition module and an implementation module. The only exception is the main module, which starts a program and does not have a definition module. Parallaxis also offers a `FOREIGN` module, which serves as the definition part for linking routines written in another language.

The sample module constellation above shows declaration, export, and import of the user-defined procedure `myproc`. It is exported in the definition module together with its procedure head, showing number and type of parameters. The actual implementation of `myproc` is hidden in the corresponding implementation module (this is also used for including routines from different programming languages). If an export list is missing in a definition module, then its whole contents is being exported.

The module importing and using procedure `myproc` in the example is the main module (it has neither keyword `DEFINITION` nor `IMPLEMENTATION`).

<pre>DEFINITION MODULE sample; EXPORT myproc; PROCEDURE myproc(VAR i: INTEGER); END sample.</pre>	<pre>MODULE mymain; FROM sample IMPORT myproc; VAR k: INTEGER; BEGIN k:=0; myproc(k); END mymain.</pre>
<pre>IMPLEMENTATION MODULE sample; PROCEDURE myproc(VAR i: INTEGER); BEGIN i := 2*i + 1 END myproc; END sample.</pre>	

There are two ways of importing objects. The first imports *individual objects* from a module, the second includes *all objects* from a module (in that case, however, an object name *always* requires the module name as a prefix, in order to avoid name conflicts):

<pre>FROM sample IMPORT myproc; ... myproc(k);</pre>	<pre>IMPORT sample; ... sample.myproc(k);</pre>
------------------------------------------------------	-------------------------------------------------

1.12 Input and Output

I/O operations in Parallax are very similar to Modula-2. However, in Parallax they are "built-in" and need not be explicitly imported as in Modula-2. This change was required, since read- and write-operations in Parallax may take either scalar or vector arguments. For vector output, spaces and line breaks are inserted to make the printout more readable.

The major text input and output operations in Parallax are shown below (ASCII data). I/O operations do *not* generate run-time errors (e.g. in case of inappropriate data to be read or in case of insufficient disk space during a write operation). Instead, the scalar boolean variable `Done` is set according to the success of the I/O operation. This variable can be checked to perform appropriate actions, in case its value is `FALSE`. When reading strings, integers, cardinals, reals, or booleans, the scalar character variable `termCH` is set to the next unread character in the input stream, which was responsible for terminating the read operation. `EOL` is a constant of type character, which stands for the system-dependent end-of-line character.

Numbers are printed right-adjusted (add leading blanks), while strings/booleans are printed left-adjusted (add trailing blanks).

<code>WriteLn;</code>	Start a new line (no arguments)
<code>Write(c);</code>	Write character <code>c</code>
<code>WriteString(s)</code>	Write string <code>s</code>
<code>WriteInt(i,l);</code>	Write integer <code>i</code> using <code>l</code> print spaces min.
<code>WriteCard(c,l);</code>	Write cardinal <code>c</code> using min. <code>l</code> print spaces min.
<code>WriteReal(r,l);</code>	Write real <code>r</code> using <code>l</code> print spaces min.

<code>WriteFixPt(r,l,m);</code>	Write real r using l print sp. min. and m decimals
<code>WriteBool(b,l);</code>	Write boolean b using l print spaces min.
<code>Read(c);</code>	Read character c
<code>ReadString(s)</code>	Read string s
<code>ReadInt(i);</code>	Read integer i
<code>ReadCard(c);</code>	Read cardinal c
<code>ReadReal(r);</code>	Read real r
<code>ReadBool(b);</code>	Read boolean b
<code>OpenOutput(s);</code>	Open file with name s for writing (following write operations write to file)
<code>CloseOutput;</code>	Close file, redirect output back to stdout
<code>OpenInput(s);</code>	Open file with name s for reading (following read operations read from file)
<code>CloseInput;</code>	Close file, redirect input back to stdin

The following gives a number of sample write operations; read operations work the same way.

```

VAR i: INTEGER;
    r: REAL;
...
WriteString("Hello"); (* write string on screen *)
WriteInt(i,7);        (* write integer value using 7 print spaces *)
WriteLn;              (* start writing in a new line *)
OpenOutput("myfile"); (* open file, redirect output to file *)
  WriteString("Hello"); (* write string to file *)
  WriteFixPt(r,9,2);    (* write r to file, 9 print spaces, 2 dec.*)
CloseOutput;         (* close file, output back to screen *)
WriteString("Hello"); (* write string on screen *)

```

1.13 Control Structures

Sequential control structures are also identical to Modula-2. Please note, that in Modula-2 (unlike Pascal) all control structures have to be terminated with keyword `END` (with the exception of `REPEAT`, which has a different terminating keyword) and all procedures/functions repeat the procedure name with the final `END` (see the following examples). All control structures may be used with scalar or vector arguments.

<code>IF x=0 THEN y:=1; z:=5</code>	<code>FOR x:=1 TO 10 DO</code>
<code>ELSE y:=2</code>	<code> y:=2*y</code>
<code>END;</code>	<code>END;</code>

<code>WHILE x>0 DO</code>	<code>REPEAT</code>
<code> x:=x-1; y:=2*y</code>	<code> x:=x DIV 2</code>
<code>END;</code>	<code>UNTIL x<7;</code>

```

LOOP x:=x-1;
  IF x<7 THEN EXIT
  END;
END;

CASE x OF
  1,3,7: z:=5; y:=3 |
  8..15: z:=1       |
  ELSE  z:=3; y:=4
END;

```

```

PROCEDURE abc(VAR c:CHAR);
(* reference parameter *)
BEGIN (* procedure *)
  ...
END abc;

PROCEDURE def(x: INTEGER): INTEGER;
(* value param. + return value *)
BEGIN (* function *)
  RETURN(x+1)
END def;

```

1.14 Relation to Modula-2

Parallaxis is a true extension of sequential Modula-2, with one exception. Nesting of *local modules* (these are nested modules within the same file) is not allowed, as an implementation restriction. However, nested imports of several modules are possible.

Besides this limitation, there are also some sequential extensions to the Modula-2 syntax. First, a comparison may have an arbitrary number of expressions. This allows range checks not possible in Modula-2, like the following:

```
IF 7 < x < 12 THEN ... END;
```

Next, the power operator ‘**’ has been included. It is also possible to specify constant records or constant arrays by using the type name as a function identifier (only for record and arrays of simple types). This is a useful feature for initializing record or array variables:

```

TYPE colorR = RECORD
  red, green, blue: INTEGER;
END;
colorA = ARRAY [1..3] OF INTEGER;
VAR c: colorR;
    d: colorA;
...
c := colorR(255,255,0);
d := colorA(0,255,255);

```

Like in the programming language C, the number and string contents of the command line parameters can be read in Parallaxis:

```

VAR i : INTEGER;
    buf: ARRAY [1..20] OF CHAR;
...
FOR i:=1 TO argc DO
  argv(i,buf);
  WriteString(buf); WriteLn;
END;

```

Mathematical and I/O operations are pre-defined in Parallaxis and do not have to be explicitly imported, as in Modula-2. This is necessary, since all the procedures and functions may take either scalar *or* vector parameters.

There is some confusion about the `MOD` operator in Modula-2 and C implementations. In Parallaxis, the result of a modulo operation will always be positive, especially an expression like $(-1) \text{ MOD } 5$ equals 4 in Parallaxis (as does $1 \text{ MOD } (-5)$), and not -1 as in C. This feature is heavily used in connection specifications, e.g. to construct a torus:

```
CONFIGURATION ring[0..max-1];
CONNECTION    left: ring[i] -> ring[(i-1) MOD max];
```

1.15 Efficiency

Most of the following comments apply only to the generation of parallel code for a SIMD system and not for the simulation on a single-processor workstation. Naturally, some Parallaxis statements require more computation time than others. This overview summarizes remarks made throughout the text.

1. PE Data Exchange

structured data exchange may be faster than unstructured data exchange

1.a especially a structured data exchange on a grid may be much faster (if it corresponds to the hardware, e.g. 100 times on a MasPar MP-2 system)

1.b a structured data exchange on a torus may be as fast as on a grid, only if the torus size equals a possible torus in hardware

1.c using the open configuration construct will cause some run-time overhead, since the connections have to be initialized

2. Reduction

2.a reduction operations require $\log_2 n$ steps for n PEs, each step comprising a data exchange and an arithmetic operation (in general this data exchange will be unstructured)

2.b using a data exchange with reduction may be very expensive and should therefore be avoided if possible (connection groups may have to be executed sequentially)

3. Front End Data Exchange

data exchange to and from the front end (`LOAD` and `STORE`), as well as read and write operations with vector data require n steps for n PEs (sequential execution)

4. Broadcasting

4.a broadcasting a single value from the front end to all PEs requires only 1 step

4.b broadcasting a single value from one PE to all other PEs requires 2 steps (1 from PE to front end plus 1 from front end to all PEs)

Chapter 2

Applications

The following sections demonstrate a number of sample algorithms programmed in Parallax-III. They cover a broad range of application areas and should inspire to get the feeling of data parallel programming.

2.1 Basic Applications

2.1.1 Cellular Automata

Cellular automata are an application area well suited to SIMD systems. Every cell can be assigned a processor and carries out the same processing instructions. One of the most prominent cellular automata is Conway's 'Game of Life', which is a two-dimensional structure changing in time. The cellular automaton shown here is simpler and only one-dimensional; however, it generates a two-dimensional image during execution (one line on every iteration). The processing instructions are conceptually simple: Every cell has only two possible states and computes its successor state from an exclusive-or of the states of its left and right neighbor. The middle cell is initialized with `TRUE` (printed as 'x'), while all of the other cells are initialized with `FALSE` (printed as empty spaces).

```
MODULE cellular_automaton;
CONST n = 79;          (* number of elements      *)
      m = (n+1) DIV 2; (* number of loops := middle *)
CONFIGURATION list [1..n];
CONNECTION left: list[i] <-> list[i-1] :right;

VAR i : INTEGER;
      val: list OF BOOLEAN;
      c : list OF ARRAY BOOLEAN OF CHAR;
          (* = ARRAY[FALSE..TRUE] OF CHAR *)
BEGIN
  val := ID(list) = m; (* Init *)
  c[FALSE] := " ";
  c[TRUE] := "X";
  FOR i := 1 TO m DO
    Write(c[val]);
    val := MOVE.left(val) <> MOVE.right(val);
  END;
END cellular_automaton.
```

The `CONFIGURATION` and `CONNECTION` declarations define a doubly linked list of PEs. For screen output of the current state of all PEs, every boolean state is converted to a

(using function `Gauss` not shown here, which returns a gaussian distributed random value). While the leaves have not yet been reached, the data values `low` and `high` are passed to the child nodes. In this method, the left child receives the values `low` and `x` as the start and end points of its line segment, while the right child receives `x` and `high`.

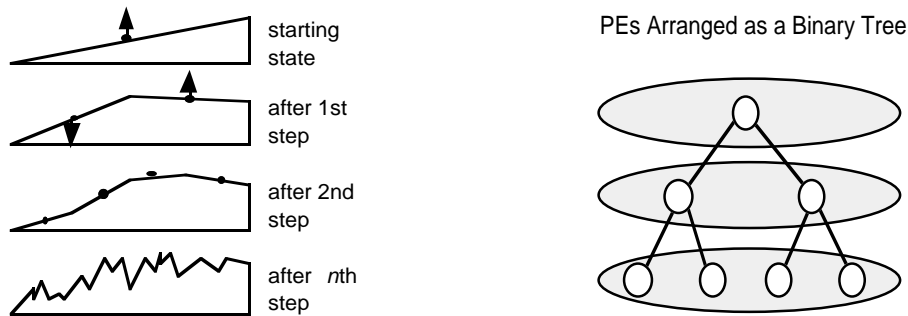

Figure 2.2: Divide-and-conquer implemented with tree topology

```

CONFIGURATION tree [1..maxnode];
CONNECTION    lchild : tree[i] <-> tree[2*i]    :parent;
              rchild : tree[i] <-> tree[2*i+1]  :parent;

VAR low, high, x: tree OF REAL;

PROCEDURE MidPoint(delta: REAL; level: INTEGER);
BEGIN  (* select level *)
  IF 2**(level-1) <= ID(tree) <= 2**level-1 THEN
    x := 0.5 * (low + high) + delta*Gauss();
    IF level < maxlevel THEN
      SEND.lchild (low,low);  (* values for children *)
      SEND.lchild (x,high);
      SEND.rchild (x,low);
      SEND.rchild (high,high);
    END;
  END;
END MidPoint;

```

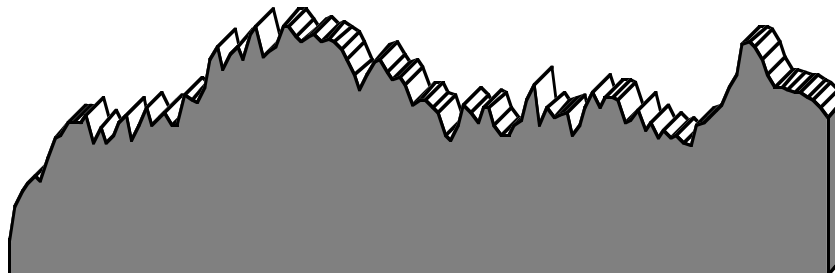

Figure 2.3: Fractal curve generated by program

The computation time required for this program is $\log_2 n$ steps for n leaf nodes (equal to the tree's height). Figure 2.3 shows a fractal curve generated by this program with 127 PEs, while Figure 2.3 shows the beginning of another fractal number sequence interpreted as fractal music.



Figure 2.4: Fractal music

2.1.3 Sorting

A number of different SIMD algorithms exist for the problem of sorting. The ‘odd-even transposition sort’ (OETS) is presented here as a representative, which can be understood as a parallel version of bubble-sort. OETS sorts n data elements with n PEs in n steps. Figure 2.5 shows the progression of the parallel algorithm. Every PE holds one of the numbers to be sorted. During processing, the algorithm differentiates between odd and even steps. In odd steps, all of the PEs with odd identification numbers compare their element values with that of their right neighbor (PEs: 1-2, 3-4, 5-6, etc.) and carry out a data exchange if the value of their own element is larger than that of their neighbor. In the even steps, all of the PEs with even identification numbers carry out an analogous comparison and, if necessary, a data exchange with their right neighbor (PEs: 2-3, 4-5, 6-7, etc.). After n iterations, the list is sorted. The right part of Figure 2.5 visualizes the algorithm, with each line in the image representing the current state of the list of PEs, while the time is progressing from top to bottom. Each pixel in a line is represented by a gray value according to its data value (low values are dark, high values are bright). In the beginning (top line), the gray values (data values) are unsorted, while they become slowly disentangled during progression of the algorithm, until the bottom line contains the gray values in perfect order. The movement of individual cells to the left or right reminds of bubble-sort.

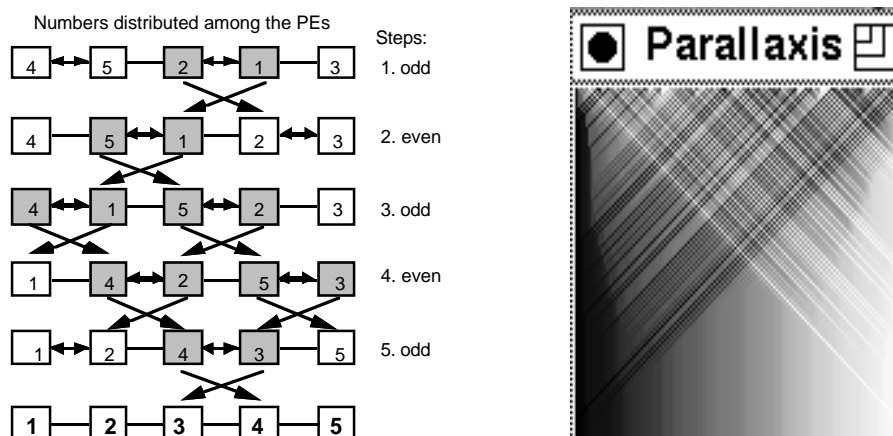

Figure 2.5: Example of odd-even transposition sorting

In the Parallaxis program, first the variable `lhs` determines whether a PE is in the role of the left or the right partner of a comparison. This role changes for each loop iteration. During each pass, the PEs get the data values of their left or right neighbor in `comp`. The partner on the left-hand side uses the right

neighbor's value for comparison, while the partner on the right-hand side uses the value of its left neighbor. The complicated comparison 'lhs = (comp<val)' is true for the left PE partner when the right comparison value is greater than its own value; it is *also* true for the right PE partner, if the left comparison value is smaller than its own value. So a single key comparison is sufficient for all PEs to find out where swapping of data values are required. By applying a more complex compound topology, the program could be optimized further, such that only a single data exchange operation would be required for each pass through the loop.

```

MODULE sort; (* Odd-Even Transposition Sorting *)
CONST n = 10;
CONFIGURATION list [1..n];
CONNECTION left : list[i] <-> list [i-1] :right;
VAR step      : INTEGER;
    a         : ARRAY[1..n] OF INTEGER;
    val,comp  : list OF INTEGER;
    lhs       : list OF BOOLEAN;

BEGIN
  WriteString('Enter 10 values: ');
  ReadInt(val);
  lhs := ODD(ID(list)); (* PE is left-hand-side of comparison *)
  FOR step:=1 TO n DO
    IF lhs THEN comp := RECEIVE.left(val)
              ELSE comp := RECEIVE.right(val)
    END;
    IF lhs = (comp<val) THEN val:=comp END;(* lhs & (comp< val) *)
    lhs := NOT lhs;                      (* or rhs & (comp>=val) *)
  END;
  WriteInt(val,5);
END sort.

```

Figure 2.6 shows the runtime behaviour of the OETS sorting algorithm for sorting of 100 numbers. The graph displays the number of active PEs (y-axis) over time (simulated program steps on x-axis). The PE load curve shows a continuous high processor utilization with repetitive steps at half load, reflecting the IF statement.

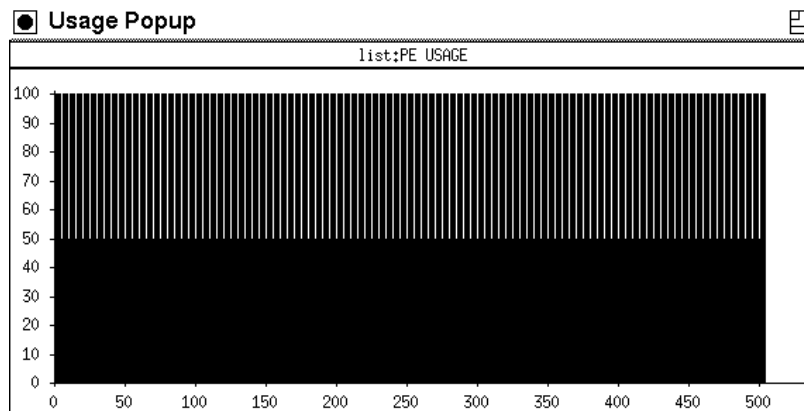

Figure 2.6: Processor utilization of the sorting algorithm

2.2 Image Processing

Many image processing operations are ideal for SIMD processing. This holds especially for local operators, which use image data only from a limited neighborhood with fast data exchange. We demonstrated the versatility of our approach for a wide range of image operations in a textbook (Bräunl et al.: *Parallele Bildverarbeitung*), which is also very well suited for course work in this area. Two of these operators will be discussed in the following.

2.2.1 Laplace Filter

The Laplace operator is one possible operator for emphasizing edges in a gray-scale image (edge detection). The operator carries out a simple local difference pattern and is therefore well suited to parallel execution. The Laplace operator is applied in parallel to each pixel with its four neighbors. Figure 2.7 shows the application of the Laplace operator with a subsequent threshold.

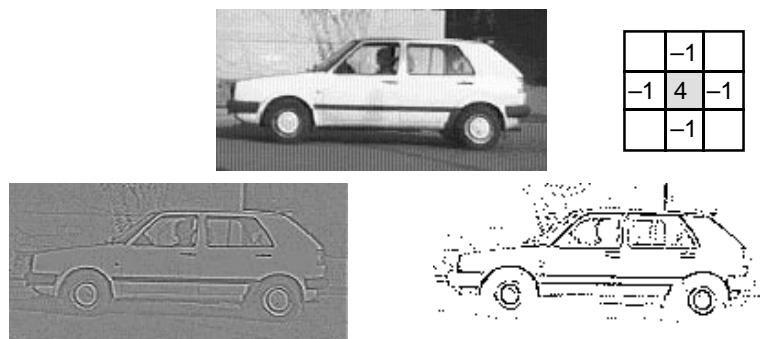

Figure 2.7: Edge detection with Laplace operator

A procedure for the Laplace operator with threshold in Parallaxis, using an open grid structure is defined in the following:

```

CONFIGURATION grid[*],[*]; (* open grid *)
CONNECTION north: grid[i,j] <-> grid[i-1,j] :south;
           east : grid[i,j] <-> grid[i,j-1] :west;
...
PROCEDURE Laplace_thres(x: grid OF INTEGER): grid OF BOOLEAN;
VAR temp: grid OF INTEGER;
BEGIN
  temp := 4*x -MOVE.north(x) -MOVE.south(x)
           -MOVE.east(x) -MOVE.west(x);
  RETURN temp > 150;
END Laplace_thres;

```

The data from neighbor PEs is obtained by local data exchange operations, which are directly used in the arithmetic expression to be returned. This simple procedure does not handle range limits for gray-scale values, e.g. [0..255].

2.2.2 Dithering

Dithering transforms a gray scale image to a binary image by converting the original gray scale intensities to black and white patterns. The apparent increase of intensity levels created by the patterns is being traded against the lower resolution in the binary image. A simple technique with fixed patterns is *ordered dithering* or *halftoning*. Figure 2.8 shows dithering with 2×2 patterns, enabling the use of five different intensities.

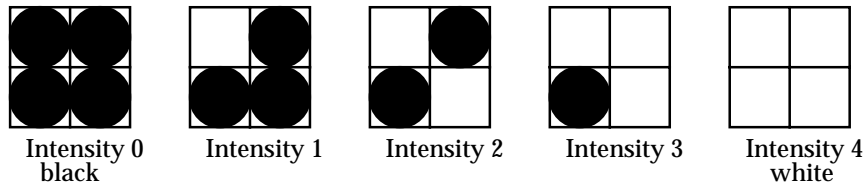

Figure 2.8: Dithering with 2×2 pattern

The following program is a parallel implementation of ordered dithering. The computation is actually performed only on every fourth PE. Three quarters of the PEs remain inactive, while only the gray scale values of the PEs in the upper left corners of each 2×2 pattern are used. The binary result pattern is set according to this gray scale value. A constant threshold (`thres`) is used to divide the whole gray scale range in five areas.

The binary result value for the upper left position (`res`) is set (*black pixel*) if the gray scale input value is less than the threshold. The binary result value for the right neighbor is set (*black pixel*) if the gray scale input value is less than three times the threshold. The remaining two neighbors are determined the same way, according to the patterns in Figure 2.8. The movement of the neighbor pixels to the right position is performed by standard procedure `SEND` (moving data to inactive PEs).

```
PROCEDURE dither_ordered(img: grid OF gray):
    grid OF binary;
CONST thres = g_white DIV 5;
VAR res: grid OF binary;
BEGIN
  IF ODD(DIM(grid,2)) AND ODD(DIM(grid,1)) THEN
    res := img < thres; (* upper left corner *)
    SEND.right (img < 3*thres,res);
    SEND.down (img < 4*thres,res);
    SEND.down_r(img < 2*thres,res);
  END;
  RETURN res;
END dither_ordered;
```

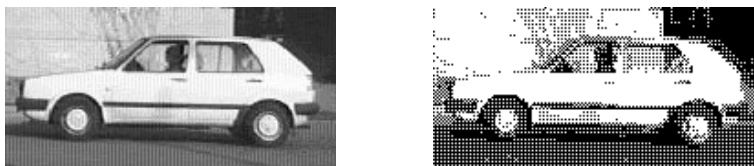

Figure 2.9: Ordered dithering

The resulting image of *ordered dithering* for 2×2 patterns can be seen in Figure 2.9. Larger patterns, e.g. 3×3 or 4×4 , may also be used.

2.3 Simulation

Many simulation models require only SIMD style computation and, furthermore, exhibit a local data exchange pattern. The simulation presented here models a very simplified behavior of cars on a single lane street. If the car concentration exceeds a certain threshold, sudden and unmotivated traffic jams occur.

For this simulation in Parallaxis, two disjoint configurations have been used. One configuration for the cars and one for the street segments. Cars may not take over each other, so they keep their linear order. The street is modeled as a closed ring.

```

CONFIGURATION cars[0..max_cars-1];
CONNECTION
  next: cars[i] <-> cars[(i+1) MOD max_cars] :back;

CONFIGURATION street[0..width-1];

VAR pos, dist,
    speed, accel: cars OF REAL;
    collision    : cars OF BOOLEAN;
    my_car      : street OF BOOLEAN;
    time, z     : INTEGER;

```

At initialization all cars are started at equal distance across the street.

```
pos := FLOAT(DIM(cars,1)) / FLOAT(max_cars);
```

The simulation itself is a large FOR-loop, which generates one graphics line for each iteration. If there is sufficient space in front of a car, it accelerates up to a maximum speed by a constant value plus a small random term. The randomness prevents all cars from maintaining identical distances from each other. Collisions are detected in parallel by measuring the distance of all pairs of subsequent cars. They cause a sudden stop, from which the cars can again accelerate in the subsequent simulation step. The integration required for determining velocity and position from acceleration has been simplified to summation.

```

FOR time := 1 TO steps DO
  ... (* show "collision" at line "time" *)
  my_car := DIM(street,1) =
    TRUNC(pos<:0:> * FLOAT(width));
  ... (* show "my_car" at line "time" *)
  dist := MOVE.back(pos) - pos;
  IF dist < 0.0 THEN dist := dist + 1.0 END;
  (* close street to loop *)

  collision := dist < 0.0;

  IF collision THEN speed := 0.0;
  ELSE (* no collision, accelerate *)
    accel := max_accel + rand_fac *
      (RandomReal(cars)-0.5);

  (* brake, if necessary *)
  IF dist < min_dist THEN accel := - max_accel END;

```

```
(* update speed, apply speed limit *)
speed := min(speed + accel, max_speed);

(* do not back up on autobahn ! *)
IF speed < 0.0 THEN speed := 0.0 END;

(* update position *)
pos := pos + speed;

(* leaving right, coming back in left *)
IF pos >= 1.0 THEN pos := pos - 1.0 END;
END;
END;
```

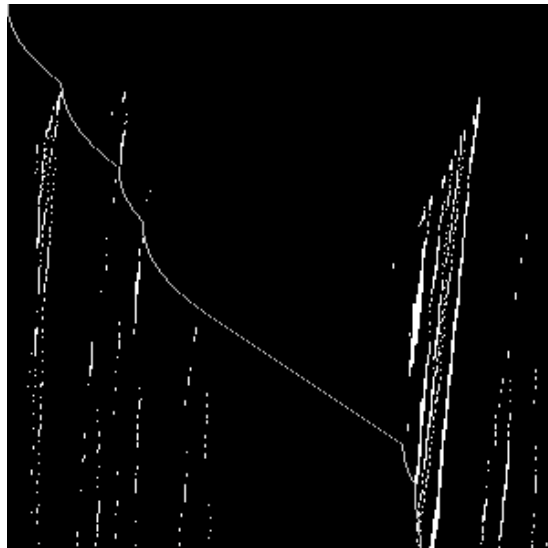

Figure 2.10: Simulation of traffic congestion

A sample simulation run of the traffic program is shown in Figure 2.10. The street is modeled as a closed ring, displayed as a horizontal line, while time flows from top to bottom in the figure. Standing cars are marked as bright spots. Also, the route of one individual car is shown, starting in the upper left corner. It is easy to recognize the acceleration phase of the individual car (parabolic curve), leading to a phase of continuous speed (straight line). Sudden breaks occur due to heavy traffic, simply caused by too many cars on the street. Several spontaneous traffic jams occur in this simulation, all slowly propagating in the direction opposite to the driving direction. Some congestions are increasing, while others are decreasing.

Chapter 3

Compiler and Debugger

Several Compilers and a source-level Debugger are the tools for the Parallaxis environment. The debugger also contains the features for performance analysis, which used to be a separate tool in earlier versions.

Figure 3.1 shows the interaction of the Parallaxis tools (shaded boxes) with standard Unix tools (white boxes) on workstations and the MasPar massively parallel system.

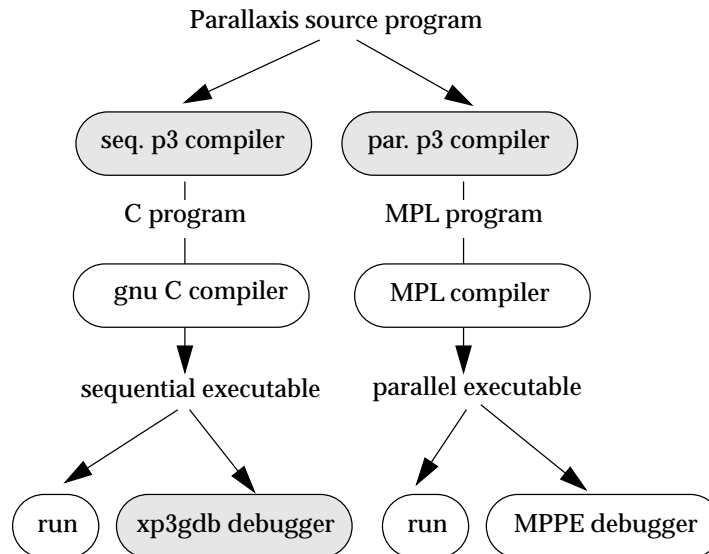

Figure 3.1: Parallaxis Tools

3.1 Compiler

We have developed several compilers for Parallaxis-III. Here, the compiler for generating sequential C-code (simulation system) will be discussed. There are further Parallaxis compilers for the MasPar MP-1/MP-2 (SIMD) and the Intel Paragon (MIMD, programmed in SPMD mode) or workstation clusters using PVM (parallel

virtual machine). All compilers generate C code (or MPL code in case of the MasPar), so a subsequent compilation step is necessary to generate object code.

The *Cocktail* compiler construction tools from GMD/Univ. Karlsruhe have been used to build the Parallaxis-III compilers. The compiler option list is shown in Figure 3.2.

NAME	p3 -- Parallaxis-III Compiler User Interface V0.5
DESCRIPTION	Compile some Parallaxis-III programs and call backend compiler.
SYNOPSIS	p3 [options] [file] ...
OPTIONS	<ul style="list-style-type: none"> -C Generate C-code for simulation (default) -casts Generate type casts to make C-programs lint free -cc name Name of the backend compiler to use -g Generate debug code (also passed to backend compiler) -h, -H, -help Print this usage -headers Generate header files for imported modules -Ipath Add path to import/include list (Par. and backend) -indent i Set indent of generated code to i blanks -koption Pass option directly to backend compiler -Lpath Add path to library path (backend only) -m, -mem Print statistics about used memory -MPL, -mpl Generate MPL-code for MasPar -n, -nocompile Don't compile, just show comands (implies -v) -nop3inc Don't use standard include paths -nop3lib Don't use standard library paths -nodefaults Same as -nop3inc -nop3lib -o name Name of the generated executable -p Parallaxis compile only, don't call backend compiler -c Paral. and backend compile only, don't call linker -Ppath Add path to import list (Parallaxis only) -PVM, -pvm Generate PVM-code for Paragon -r, -rchecks Don't generate runtime range checks -s, -small Generate small MPL-only model (max. 128KB) -t, -time Print statistics about used time (Parallaxis only) -tt, -total Like -t, but also for backend compiler -v Print version of p3 and the resulting compiler calls -vv Like -v, passes also -v to backend compiler -w Don't generate warnings -ww Like -w, passes also -w to backend compiler
OPTIONS ONLY AVAILABLE DURING DEVELOPMENT	<ul style="list-style-type: none"> -Zw Write code tree -Zs Write symbols tree -Zq Query code tree -Zc Check code tree -Zl Run parser only, no semantic check -Z2 Run parser and semantic check only, no code generation
	Every other option is passed unchanged to the backend compiler.
ENVIRONMENT	<ul style="list-style-type: none"> P3CC Name of the backend compiler P3INC ":"-seperated list of paths where to find sources P3LIB ":"-seperated list of paths where to find libraries P3OPT Default options always to set

Figure 3.2: Compiler options

The configurations of Parallaxis, i.e. the PEs, are implemented by linear arrays. Each configuration keeps track about which (virtual) PEs are active and which are not (the "active-set" of the configuration).

3.2 Debugger

A compiler just by itself is not sufficient for parallel program development or even for education purposes. Therefore, we decided to develop also a source level debugger for Parallaxis. Despite starting from scratch, we used the gnu debugger *gdb* and its graphics interface *xxgdb* as a base. First, this C debugger had to be taught to behave as if being a Parallaxis source level debugger. This affects not only the source line window and the positioning of break points, but also (and more difficult) the presentation of Parallaxis data types, especially vector data.

The command names are:

```
p3gdb          for the Parallaxis/gnu debugger in text mode
xp3gdb        for the Parallaxis/gnu debugger in graphics mode
```

Figure 3.3 shows an excerpt of the debugger man page, while Figure 3.4 shows a typical sample debugging session.

Second, we added a number of graphics facilities. Especially for large vectors (e.g. two-dimensional image or simulation data), it is not very entertaining to examine large lists of data. Instead we provided the possibility to look at vector data *directly* in a graphics window. One- or two-dimensional data is displayed in a window with little boxes representing individual PEs (Figure 3.5). Each box is colored (rainbow colors or gray scale) according to its data value, and drawn hollow if inactive. Position numbers may be added and the data range may be fixed. The vector window can display a static state (command *print*) or adapt dynamically to changing data (command *display*).

The PE usage may also be displayed graphically. Here, the program is executed in single step mode and the number of active PEs is determined at each step. Due to the overhead of stepwise evaluation, execution time slows down when using this feature. The PE usage values produce a tell-tale curve of the application program's parallel characteristics and are a valuable help in localizing critical program regions for optimization of the execution time. Figure 3.6 shows the PE usage curve for the prime sieve sample program.

```
MODULE prime;
CONFIGURATION list [2..200];
CONNECTION (* none *);
VAR next_prime: INTEGER;
    removed   : list OF BOOLEAN;
BEGIN
  REPEAT
    next_prime:= REDUCE.FIRST(DIM(list,1));
    WriteInt(next_prime,10); WriteLn;
    removed := DIM(list,1) MOD next_prime =0
  UNTIL removed
END prime.
```

```

NAME
    xp3gdb - X window system interface to the p3gdb debugger.

SYNOPSIS
    xp3gdb [ -toolkitoption ... ] [-xp3gdboption ... ] [-
    gdboption ... ] [objfile [ corefile ]]

DESCRIPTION
    Xp3gdb is a graphical user interface to the gdb debugger
    under the X Window System. It provides visual feedback and
    mouse input for the user to control program execution
    through breakpoints, to examine and traverse the function
    call stack, to display values of variables and data struc-
    tures, and to browse source files and functions.
...
Special Vector Commands
PE USAGE
    Pop up a window with a graphical representation of the
    amount of processors in use for a special configura-
    tion. When clicking in the command widget on top of the
    window, a menu will pop up. The style of view can be
    changed through the Settings entry between solid and
    point, absolute and relative. Scale lines can be
    activated. Also horizontal zooming can be modified.
    Vertical zooming is done automatically, depending on
    the window size.

    Through the menu entry Save values the current usage
    values can be saved into a file. The format of the file
    is:
        # Maximum:
        integer
        # PEs in use follow this line
        integer
        integer
        ...
    Lines starting with # are comment lines. The first
    non-comment line specifies the total number of proces-
    sors within this configuration, all other lines specify
    the number of active prozessors through the steps done
    so far.

print VECTOR
    Pop up a window with a graphical display of the current
    content for a vector variable. Currently only grids and
    lists are supported for processor configurations. All
    other configurations will be mapped to one of these.
    When clicking in the command widget on top of the win-
    dow, a menu will pop up with various selections.

disp VECTOR
    Will pop up the same window as for print VECTOR, except
    that the displayed variable will be refreshed automati-
    cally each time execution is stopped.

```

Figure 3.3: Debugger commands

xp3gdb 0.93

/home/braun/tmp/matrix.pm 23

```

shiftB: grid[i,j] -> grid[(i-j) MOD max,j];

VAR i,j : INTEGER;
a,b,c: grid OF REAL;

PROCEDURE matrix_mult(VAR a,b,c : grid OF REAL);
VAR k: INTEGER; (* c := a * b *)
BEGIN
  a := MOVE.shiftA(a);
  b := MOVE.shiftB(b);
  c := a * b;
  FOR k := 2 TO max DO
    a := MOVE.left(a);
    b := MOVE.up (b);
    c := c + a * b;
  END;
END matrix_mult;

BEGIN
(* preset input matrices "a" and "b" (or read from file) *)
a := FLOAT(DIM(grid,2) * 10 + DIM(grid,1)); WriteFixPt(a,7,1);
b := FLOAT(DIM(grid,2) + DIM(grid,1)); WriteFixPt(b,7,1);

matrix_mult(a,b,c); WriteFixPt(c,7,1);

```

Current language: auto; currently parallaxis-3

run	cont	next	step	finish	break
tbreak	delete	delete all	up	down	print
print *	print VECTOR	display	disp VECTOR	undisplay	undisplay all
show display	args	locals	stack	edit	search
interrupt	file	show brkpts	yes	no	quit

80,0	81,0	82,0	83,0	84,0	85,0	86,0	87,0	88,0	89,0
90,0	91,0	92,0	93,0	94,0	95,0	96,0	97,0	98,0	99,0
0,0	1,0	2,0	3,0	4,0	5,0	6,0	7,0	8,0	9,0
1,0	2,0	3,0	4,0	5,0	6,0	7,0	8,0	9,0	10,0
2,0	3,0	4,0	5,0	6,0	7,0	8,0	9,0	10,0	11,0
3,0	4,0	5,0	6,0	7,0	8,0	9,0	10,0	11,0	12,0
4,0	5,0	6,0	7,0	8,0	9,0	10,0	11,0	12,0	13,0
5,0	6,0	7,0	8,0	9,0	10,0	11,0	12,0	13,0	14,0
6,0	7,0	8,0	9,0	10,0	11,0	12,0	13,0	14,0	15,0
7,0	8,0	9,0	10,0	11,0	12,0	13,0	14,0	15,0	16,0
8,0	9,0	10,0	11,0	12,0	13,0	14,0	15,0	16,0	17,0
9,0	10,0	11,0	12,0	13,0	14,0	15,0	16,0	17,0	18,0

Breakpoint 1, mult (a#grid=0x112c0, b#grid=0x115e0, c#grid=0x11900) at matrix.pm:23
Current language: auto; currently parallaxis-3
(xp3gdb)

Figure 3.4: Debugger Control Window

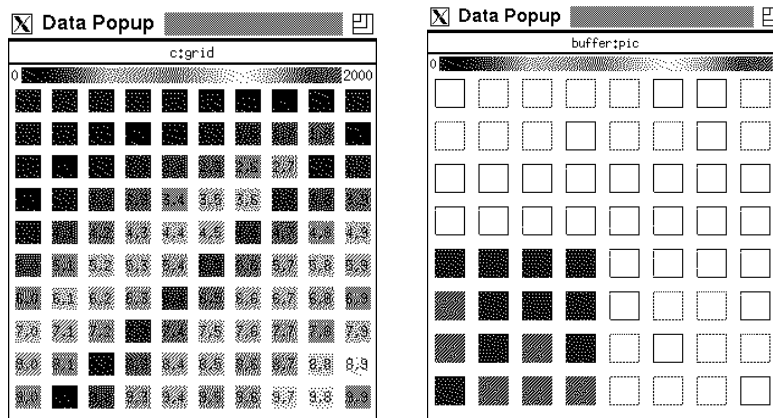

Figure 3.5: Vector display

This tiny program represents the parallel version of the sieve of Eratosthenes. The list of active PEs resembles the candidates for prime numbers not yet removed. In the beginning all PEs are active, which is reflected by the initial peak in Figure 3.6. But in each step of the `REPEAT` loop, variable `removed` becomes true for all multiples of the just found prime, whose PEs will no longer be active in the next iteration of the loop. This explains the exponentially-like decrease in the PE usage diagram.

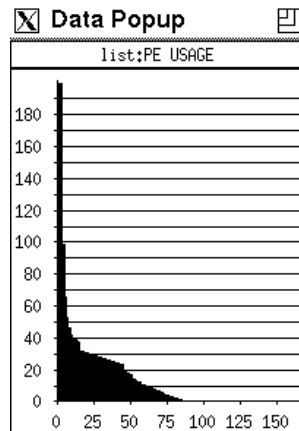

Figure 3.6: PE usage

Chapter 4

Appendix

4.1 Data Types

Parallaxis supports all data types available in Modula-2:

INTEGER	integer numbers (4 bytes)
CARDINAL	integer numbers greater or equal to 0 (4 bytes)
REAL	floating point numbers (8 bytes)
CHAR	character values (1 byte), ordinal values ranging from 0 to 255
BOOLEAN	truth values (1 byte), equal to (FALSE, TRUE)
ARRAY .. OF ..	array of data values
RECORD .. END	collecting several entries to a structured type
SET OF ..	set of a simple type
BITSET	equivalent to SET OF [0..31]
POINTER TO ..	pointer to a type, data has to be allocated dynamically
PROCEDURE (..)	procedure or function type, e.g. <code>TYPE function = PROCEDURE (REAL): REAL;</code>
<i>enumeration</i>	enumerating all values of a type (1 byte) e.g. <code>TYPE day = (mo, tu, we, th, fr, sa, su);</code>
<i> subrange</i>	limited range of values (from 1 to 4 bytes) e.g. <code>TYPE workday = [mo..fr];</code> <code>digit = [0..9];</code>

4.2 Built-in Functions and Procedures

All built-in functions and procedures may be called with either scalar or vector arguments. The return value of such a function is scalar if its argument is scalar, and vector if its argument is vector. Type `INTEGER` always includes type `CARDINAL`.

In Modula-2, mathematical functions and I/O-procedures are separate modules and their objects have to be imported. In Parallaxis, however, all these functions and procedures can be used with either scalar or vector arguments. Therefore, they had to be included as built-in functions and procedures.

General Functions

<code>FLOAT(i)</code>	return real value of integer <i>i</i>
<code>TRUNC(r)</code>	return value of real <i>r</i> , truncated to an integer

ABS(<i>i</i>)	return absolute value of <i>i</i> , type Integer or Real
CHR(<i>i</i>)	return character with ordinal number <i>i</i>
VAL(<i>t</i> , <i>i</i>)	return value of type <i>t</i> with ordinal number <i>i</i>
ORD(<i>c</i>)	return ordinal number of <i>c</i> for character or enumeration type, starting with 0
MAX(<i>t</i>)	return maximum value of type <i>t</i>
MIN(<i>t</i>)	return minimum value of type <i>t</i>
SIZE(<i>t</i>)	return number of bytes required for a variable of type <i>t</i>
HIGH(<i>a</i>)	return upper bound of open array <i>a</i>
ODD(<i>i</i>)	return " <i>i</i> MOD 2 <> 0", type integer or char
EVEN(<i>i</i>)	return " <i>i</i> MOD 2 = 0", type integer or char
CAP(<i>c</i>)	return capital character, corresponding to <i>c</i>

General Procedures

NEW(<i>p</i>)	allocate memory for a new data element, set <i>p</i> to address
DISPOSE(<i>p</i>)	deallocate memory for the element pointed to by <i>p</i> pointer data type is POINTER TO base_type nil element is NIL for NEW and DISPOSE, it is required (like in Modula-2) to import procedures ALLOCATE and DEALLOCATE from module STORAGE
DEC(<i>i</i>)	<i>i</i> := <i>i</i> - 1, type integer or character
DEC(<i>i</i> , <i>n</i>)	<i>i</i> := <i>i</i> - <i>n</i> , type integer or character
INC(<i>i</i>)	<i>i</i> := <i>i</i> + 1, type integer or character
INC(<i>i</i> , <i>n</i>)	<i>i</i> := <i>i</i> + <i>n</i> , type integer or character
EXCL(<i>s</i> , <i>n</i>)	exclude element <i>n</i> from set <i>s</i>
INCL(<i>s</i> , <i>n</i>)	add element <i>n</i> to set <i>s</i>
HALT	terminate program execution

Command Line Arguments

PROCEDURE argc: CARDINAL;	number of command line parameters
PROCEDURE argv(index: CARDINAL; VAR arg: ARRAY OF CHAR);	get command line parameters (range 1..argc)

Mathematical Functions

The following functions have real arguments and return real values (scalar or vector).

pi	constant $\pi = 3.1415926535897932385$
sqrt(<i>r</i>)	square root, \sqrt{r}
exp(<i>r</i>)	exponent, e^r
ln(<i>r</i>)	natural logarithm, $\ln(r)$

<code>sin(r)</code>	sine
<code>arcsin(r)</code>	arcus sine, range -1 .. +1
<code>cos(r)</code>	cosine
<code>arccos(r)</code>	arcus cosine, range -1 .. +1
<code>tan(r)</code>	tangent
<code>arctan(r)</code>	arcus tangent, range $-\pi/2$.. $+\pi/2$
<code>arctan2(r1,r2)</code>	arcus tangent of r_1 / r_2 in range $-\pi$.. $+\pi$

The following functions have real arguments and return integer values.

<code>ceiling(r)</code>	round r to the next higher integer
<code>floor(r)</code>	round r to the next lower integer
<code>round(r)</code>	round r to the closest integer

The following functions generate random numbers. For the parallel versions, a vector variable may be used in lieu of a configuration name `conf`.

<code>RandomInt()</code>	generate a scalar integer random (MIN(INTEGER) .. MAX(INTEGER))
<code>RandomCard()</code>	generate a scalar cardinal random (0 .. MAX(CARDINAL))
<code>RandomReal()</code>	generate a scalar real random number (0.0 .. 1.0)
<code>RandomChar()</code>	generate a scalar character random value (CHR(0 .. 255))
<code>RandomBool()</code>	generate a scalar boolean random value (TRUE or FALSE)
<code>RandomInt(conf)</code>	generate a vector integer random (0 .. MAX(INTEGER))
<code>RandomCard(conf)</code>	generate a vector cardinal random (0 .. MAX(CARDINAL))
<code>RandomReal(conf)</code>	generate a vector real random number (0.0 .. 1.0)
<code>RandomChar(conf)</code>	generate a vector character random value (CHR(0 .. 255))
<code>RandomBool(conf)</code>	generate a vector boolean random value (TRUE or FALSE)

Input/Output Procedures

The following procedures may take either scalar or vector arguments. I/O operations do *not* generate run-time errors, but set the scalar boolean variable `Done` according to the success of the operation. All read operations besides `Read` set the scalar character variable `termCH`.

Vector data is printed in ascending `ID` order for all active PEs. Some rudimentary formatting is performed, when printing vector data. All integer, real, boolean, or string *vector* data (but not vector characters) will be separated by blanks when printed. A carriage return (new line) is inserted after the end of each dimension (e.g. this will print a two-dimensional vector in matrix format).

Numbers are printed right-adjusted (add leading blanks), while strings/booleans are printed left-adjusted (add trailing blanks).

<code>WriteLn</code>	Start a new line (no arguments)
<code>Write(c)</code>	Write character c
<code>WriteString(s)</code>	Write string s
<code>WriteInt(i,l)</code>	Write integer i using l print spaces
<code>WriteCard(c,l)</code>	Write cardinal c using l print spaces
<code>WriteReal(r,l)</code>	Write real r using l print spaces
<code>WriteFixPt(r,l,m)</code>	Write real r using l print spaces and m decimals
<code>WriteBool(b,l)</code>	Write boolean b using l print spaces
<code>Read(c)</code>	Read character c

ReadString(<i>s</i>)	Read string <i>s</i>
ReadInt(<i>i</i>)	Read integer <i>i</i>
ReadCard(<i>c</i>)	Read cardinal <i>c</i>
ReadReal(<i>r</i>)	Read real <i>r</i>
ReadBool(<i>b</i>)	Read boolean <i>b</i>

The following procedures take scalar arguments only.

OpenOutput(<i>s</i>)	Open file with name <i>s</i> for writing (if <i>s</i> is empty, then the user is prompted for a file name; following write operations write to file)
CloseOutput	Close file, redirect output back to <i>stdout</i>
OpenInput(<i>s</i>)	Open file with name <i>s</i> for reading (if <i>s</i> is empty, then the user is prompted for a file name; following read operations read from file)
CloseInput	Close file, redirect input back to <i>stdin</i>

Vector Functions

For the following functions and procedures, who take a configuration name as argument, a vector variable may be used in lieu of a configuration name.

Argument *num* is a positive integer, *dims* is a vector array of integers.

ID(<i>conf</i>)	returns a vector of identification numbers from 1 to LEN(<i>conf</i>) for configuration <i>conf</i>
DIM(<i>conf</i> , <i>num</i>)	returns a vector of position numbers according to the dimension declaration of <i>conf</i> , dimensions are numbered from <i>right to left</i> from 1 to RANK(<i>conf</i>)
LEN(<i>conf</i>)	returns the total number of PEs of a configuration
LEN(<i>conf</i> , <i>num</i>)	returns the size of dimension <i>num</i>
RANK(<i>conf</i>)	returns the number of dimensions
UPPER(<i>conf</i> , <i>num</i>)	returns the upper bound of dimension <i>num</i>
LOWER(<i>conf</i> , <i>num</i>)	returns the lower bound of dimension <i>num</i>
DIM2ID(<i>conf</i> , <i>dims</i>)	transforms the appropriate number of dim-values into the corresponding id-value, may be used with scalar or vector parameters
MOVE. <i>dir</i> (<i>val</i>)	data transfer in predefined direction <i>dir</i> , sender and receiver have to be active
RECEIVE. <i>dir</i> (<i>val</i>)	data transfer in predefined direction <i>dir</i> , only receiver has to be active
REDUCE. <i>func</i> (<i>val</i>)	reduces vector <i>val</i> to a scalar value, by applying <i>func</i> (predefined: SUM, PRODUCT, MAX, MIN, AND, OR, FIRST, LAST, or user function with two input parameters and a return value of identical type)

Vector Procedures

ID2DIM(<i>conf</i> , <i>num</i> , <i>dims</i>)	transforms an id-value into an array of corre- sponding dim-values, may be used with scalar or vector parameters
SEND. <i>dir</i> (<i>val</i> , <i>var</i>)	data transfer in predefined direction <i>dir</i> , variable <i>var</i> receives expression <i>val</i> , only sender has to be active

4.3 Graphics Interface

X Window Graphics

Module `Graphics` provides a convenient interface in Parallaxis for generating graphics, based on the X window system. Type `CARDINAL` restricts `INTEGER` to positive numbers (≥ 0).

```

1  DEFINITION MODULE Graphics;
2  (* ***** *)
3  (* created: T. Braunl, 12.Apr.94 *)
4  (* ***** *)
5
6  FROM ImageIO IMPORT binary, gray, color;
7
8  TYPE window = CARDINAL;
9  CONST GrOK          = 0;
10     GrWrongWindowSize = 1;
11     GrMemoryTrouble   = 2;
12     GrWindowCreationFailure = 3;
13     GrNotExistingWindow = 4;
14     GrNoWindowSelected = 5;
15     GrWrongCoordinates = 6;
16     GrWrongColors     = 7;
17
18  VAR GraphicsError : CARDINAL;
19     (* will be set to the outcome of each graphics operation, 0 = OK *)
20
21  PROCEDURE OpenWindow(title: ARRAY OF CHAR; width,height: CARDINAL): window;
22  PROCEDURE OpenWindowP(title: ARRAY OF CHAR; width,height: CARDINAL): window;
23     (* open new window, version "P" for private colormap *)
24  PROCEDURE CloseWindow(window_num: window);
25  PROCEDURE SelectWindow(window_num: window);
26     (* OpenWindow: Open a new window of specified title and size in *)
27     (* pixels, return window number, activate new window *)
28     (* OpenWindowP: same a OpenWindow, but use private colormap for *)
29     (* this window *)
30     (* CloseWindow: close window; SelectWindow: activate window *)
31
32  PROCEDURE GetScreenSize(VAR width,height: CARDINAL);
33  PROCEDURE GetWindowSize(VAR width,height: CARDINAL);
34     (* Returns size in pixels of whole screen or active window, resp. *)
35
36  PROCEDURE SetArea (c: VECTOR OF color);
37  PROCEDURE SetgArea(c: VECTOR OF gray);
38  PROCEDURE SetbArea(c: VECTOR OF binary);
39  PROCEDURE SetAreaXYZ (c: VECTOR OF color; x,y,zoom: INTEGER);
40  PROCEDURE SetgAreaXYZ(c: VECTOR OF gray; x,y,zoom: INTEGER);
41  PROCEDURE SetbAreaXYZ(c: VECTOR OF binary; x,y,zoom: INTEGER);
42     (* All active PEs write one pixel each, assuming a 2-dim. grid *)
43     (* configuration of appropriate size, image will be truncated or *)
44     (* left partly unchanged if PE grid size does not match image size *)

```

```

45      (* origin is top left corner with coordinates 0, 0          *)
46      (* version "g" for gray data, version "b" for binary data    *)
47      (* versions "XYZ" with offset and zoom (both pos. or neg.)  *)
48      (* zoom range determines pixel size, negative zoom reduces size *)
49
50  PROCEDURE SetLine (c: VECTOR OF color; line: CARDINAL);
51  PROCEDURE SetgLine(c: VECTOR OF gray; line: CARDINAL);
52  PROCEDURE SetbLine(c: VECTOR OF binary; line: CARDINAL);
53  PROCEDURE SetLineZ (c: VECTOR OF color; line: CARDINAL; offset, zoom: INTEGER);
54  PROCEDURE SetgLineZ(c: VECTOR OF gray; line: CARDINAL; offset, zoom: INTEGER);
55  PROCEDURE SetbLineZ(c: VECTOR OF binary; line: CARDINAL; offset, zoom: INTEGER);
56      (* print PE data along specified line, top line has no. 0 *)
57      (* versions "Z" get offset and zoom according to specification *)
58      (* from SetArea routines. *)
59
60  PROCEDURE SetColumn (c: VECTOR OF color; col: CARDINAL);
61  PROCEDURE SetgColumn(c: VECTOR OF gray; col: CARDINAL);
62  PROCEDURE SetbColumn(c: VECTOR OF binary; col: CARDINAL);
63  PROCEDURE SetColumnZ (c: VECTOR OF color; col: CARDINAL; offset, zoom: INTEGER);
64  PROCEDURE SetgColumnZ(c: VECTOR OF gray; col: CARDINAL; offset, zoom: INTEGER);
65  PROCEDURE SetbColumnZ(c: VECTOR OF binary; col: CARDINAL; offset, zoom: INTEGER);
66      (* print PE data along specified column, leftmost line has no. 0 *)
67      (* versions "Z" get offset and zoom according to specification *)
68      (* from SetArea routines. *)
69
70  PROCEDURE SetColor (c: color);
71  PROCEDURE SetgColor(c: gray);
72  PROCEDURE SetbColor(c: binary);
73      (* Specify color for subsequent pixel/line/draw commands *)
74      (* "g" and "b" version for gray and binary data *)
75
76  PROCEDURE SetPixel(x,y: CARDINAL);
77  PROCEDURE GetPixel(x,y: CARDINAL): color;
78  PROCEDURE Line(x1,y1, x2,y2: CARDINAL);
79      (* scalar functions for writing or reading a single pixel *)
80      (* scalar line: straight line from x1,y1 to x2,y2 *)
81
82  PROCEDURE DrawAt(x,y: CARDINAL);
83      (* Set drawing position for subsequent drawing commands *)
84      (* initialized with lower left character position (1,1) *)
85      (* position will be updated by each drawing command *)
86
87  PROCEDURE Draw (c: CHAR);
88  PROCEDURE DrawString(s: ARRAY OF CHAR);
89  PROCEDURE DrawInt (i,l: INTEGER);
90  PROCEDURE DrawCard (c,l: CARDINAL);
91  PROCEDURE DrawReal (r: REAL; l: CARDINAL);
92  PROCEDURE DrawFixPt (r: REAL; l,m: CARDINAL);
93  PROCEDURE DrawBool (b: BOOLEAN; l: CARDINAL);
94  PROCEDURE DrawLn;
95      (* amount of l print spaces is always minimum *)
96      (* Draw character c in window *)

```

```

97         (* Draw string s in window *)
98         (* Draw integer/cardinal i in window *)
99         (* Draw real r in window *)
100        (* Draw with fix point, using m decimals *)
101        (* Draw boolean value b in window left adjusted *)
102        (* DrawLn set drawing position to new line *)
103        (* Total line width depends on used font ($PARALLAXIS_FONT), *)
104        (* new line vertical placement also. *)
105
106    END Graphics.

```

Image File Transfer

Module `ImageIO` contains a number of operations for reading images from files and writing images to files (no X window interface is needed). The binary versions of the PPM (portable pixel map) file format are used for color, gray scale, and binary images.

```

1  DEFINITION MODULE ImageIO;
2  (* created: T. Braunl, Oct.94 *)
3  (* ***** *)
4  (* read_c_image  read color image in ppm P6 format *)
5  (*              into a vector variable *)
6  (* read_g_image  read gray image in ppm P5 format *)
7  (* read_b_image  read binary image in ppm P4 format *)
8  (*              *)
9  (* write_c_image write color image in P6 format *)
10 (* write_g_image write gray image in P5 format *)
11 (* write_b_image write binary image in P4 format *)
12 (*              *)
13 (* PE-ID 1 (origin) is top left *)
14 (* ***** *)
15
16 TYPE binary = BOOLEAN;
17     gray   = [0..255];
18     color  = RECORD
19         red, green, blue: gray
20     END;
21
22 CONST b_black   = TRUE;
23        b_white  = FALSE;
24        g_black  = 0;
25        g_white  = 255;
26        c_black  = color( 0, 0, 0);
27        c_white  = color(255,255,255);
28        c_red    = color(255, 0, 0);
29        c_green  = color( 0,255, 0);
30        c_blue   = color( 0, 0,255);
31
32 PROCEDURE read_c_image (VAR im: VECTOR OF color; filename: ARRAY OF CHAR;
33                        VAR width,height: CARDINAL);
34 PROCEDURE read_g_image (VAR im: VECTOR OF gray; filename: ARRAY OF CHAR;
35                        VAR width,height: CARDINAL);

```

```
36 PROCEDURE read_b_image (VAR im: VECTOR OF binary; filename: ARRAY OF CHAR;  
37                       VAR width,height: CARDINAL);  
38  
39 PROCEDURE write_c_image (im: VECTOR OF color; filename: ARRAY OF CHAR;  
40                       width,height: CARDINAL);  
41 PROCEDURE write_g_image (im: VECTOR OF gray; filename: ARRAY OF CHAR;  
42                       width,height: CARDINAL);  
43 PROCEDURE write_b_image (im: VECTOR OF binary; filename: ARRAY OF CHAR;  
44                       width,height: CARDINAL);  
45  
46 END ImageIO.
```

4.4 Parallaxis-III Syntax

Parallaxis-III Syntax is specified in EBNF (Extended Backus-Naur-Form).

1	CompilationUnit	=	ProgramModule DefinitionModule ImplementationModule ForeignModule .
2	ProgramModule	=	MODULE Ident ';' { Import } Block Ident ' .
3	DefinitionModule	=	DEFINITION MODULE Ident ' { Import } [Export] { Definition } END Ident ' .
4	ImplementationModule	=	IMPLEMENTATION MODULE Ident ' { Import } Block Ident ' .
5	ForeignModule	=	FOREIGN MODULE Ident ' { Import } [Export] { Definition } END Ident ' .
6	Definition	=	CONFIGURATION {ConfigDeclaration ';' } CONNECTION { ConnectionDeclaration ';' } CONST {ConstantDeclaration ';' } TYPE {Ident ['=' GeneralType] ';' } VAR {VariableDeclaration ';' } ProcedureHeading ' .
7	Import	=	[FROM Ident] IMPORT IdentList ' .
8	Export	=	EXPORT [QUALIFIED] IdentList ' .
9	Block	=	{Declaration } [BEGIN StatementSequence] END .
10	Declaration	=	CONFIGURATION {ConfigDeclaration ';' } CONNECTION {ConnectionDeclaration ';' } CONST {ConstantDeclaration ';' } TYPE {TypeDeclaration ';' } VAR {VariableDeclaration ';' } ProcedureDeclaration ' .
11	ConfigDeclaration	=	Config { ';' Config } .
12	Config	=	[Ident ConfigRange Ident '=' Qualident ConfigRange Ident ConfigRange '=' Qualident] .
13	ConfigRange	=	'[' ConstExpression '..' ConstExpression]' '[' '*']' .
14	ConnectionDeclaration	=	TransferFunction FOR Ident ':=' Expression TO Expression DO TransferFunction { ';' TransferFunction } END .
15	TransferFunction	=	[Direction ':' Qualident '[' Source { ',' Source }]' ('-'>' Dest1 { ',' Dest1 } '<->' Dest2 { ',' Dest2 })]
16	Direction	=	Ident ['[' Source ']'] .
17	Source	=	Ident Integer String '*' .
18	Dest1	=	[Discriminant] Qualident '[' DestExprList ']' .
19	Dest2	=	[Discriminant] Qualident '[' DestExprList ']' ':' Ident ['[' Expression ']'] .

20	DestExprList	=	DestExpr {',' DestExpr } .
21	DestExpr	=	Expression Expression '..' Expression '*' .
22	Discriminant	=	'{ Expression }' .
23	ConstantDeclaration	=	Ident '=' ConstExpression .
24	ConstExpression	=	Expression .
25	TypeDeclaration	=	Ident '=' GeneralType .
26	GeneralType	=	SimpleType GeneralArrayType GeneralRecordType SetType PointerType ProcedureType (VECTOR Qualident) [Qualident] OF ScalarType .
27	ScalarType	=	SimpleType ScalarArrayType ScalarRecordType SetType PointerType ProcedureType .
28	GeneralArrayType	=	ARRAY SimpleType {',' SimpleType } OF GeneralType .
29	GeneralRecordType	=	RECORD FieldListSequence1 END .
30	FieldListSequence1	=	[FieldList1 {',' FieldList1 }] .
31	FieldList1	=	IdentList ':' GeneralType CASE [Ident] ':' Qualident OF Variant { ' ' Variant } [ELSE FieldListSequence2] END .
32	Variant	=	[CaseLabelList ':' FieldListSequence2] .
33	CaseLabelList	=	CaseLabels {',' CaseLabels } .
34	CaseLabels	=	ConstExpression ['..' ConstExpression] .
35	ScalarArrayType	=	ARRAY SimpleType {',' SimpleType } OF ScalarType .
36	ScalarRecordType	=	RECORD FieldListSequence2 END .
37	FieldListSequence2	=	[FieldList2 {',' FieldList2 }] .
38	FieldList2	=	IdentList ':' ScalarType CASE [Ident] ':' Qualident OF Variant { ' ' Variant } [ELSE FieldListSequence2] END .
39	SimpleType	=	Qualident Enumeration SubrangeType .
40	Enumeration	=	'(IdentList)' .
41	SubrangeType	=	[Qualident] '[' ConstExpression '..' ConstExpression ']' .
42	SetType	=	SET OF SimpleType .
43	PointerType	=	POINTER TO GeneralType .
44	ProcedureType	=	PROCEDURE [FormalTypeList] .
45	FormalTypeList	=	'([[VAR] FormalType {',' [VAR] FormalType }])' [':' [(VECTOR Qualident) OF] Qualident .

46	FormalType	=	[(VECTOR Qualident) OF] [ARRAY OF] Qualident .
47	VariableDeclaration	=	IdentList ':' GeneralType .
48	ProcedureDeclaration	=	ProcedureHeading ';' Block Ident .
49	ProcedureHeading	=	PROCEDURE Ident [FormalParameters] .
50	FormalParameters	=	'([Parameter { ';' Parameter }])' [':' Qualident] .
51	Parameter	=	[VAR] IdentList ':' FormalType .
52	StatementSequence	=	Statement { ';' Statement } .
53	Statement	=	[Assignment ProcedureCall IfStatement CaseStatement WhileStatement RepeatStatement LoopStatement ForStatement WithStatement EXIT RETURN [Expression] AllStatement SendStatement LoadStatement StoreStatement] .
54	Assignment	=	Designator ':=' Expression .
55	ExprList	=	Expression { ',' Expression } .
56	Expression	=	SimpleExpression { RelationOperator SimpleExpression } .
57	RelationOperator	=	'=' '#' '<>' '<' '<=' '>' '>=' IN .
58	SimpleExpression	=	['+' '-'] Term { AddOperator Term } .
59	AddOperator	=	'+' '-' OR .
60	Term	=	Power { MulOperator Power } .
61	MulOperator	=	'*' '/' DIV MOD AND '&' .
62	Power	=	Factor { '**' Factor } .
63	Factor	=	Number String Set Designator [ActualParameters] MoveFunction ReceiveFunction ReduceFunction ArrayInitializer RecordInitializer '(' Expression)' NOT Factor '~' Factor .
64	Set	=	[Qualident] '{ [Element { ',' Element }] }' .
65	Element	=	ConstExpression ['.' ConstExpression] .
66	ActualParameters	=	'([ExprList])' .
67	MoveFunction	=	MOVE ':' DirSpecifier '(' Expression)' .

68	DirSpecifier	= Ident ['[' Expression ']'] [':' ReductIdent] '<<' Expression '>>' [':' ReductIdent] '<:' Dimension { ',' Dimension } '>' [':' ReductIdent].
69	SendSpecifier	= Ident ['[' Expression ']'] [':' StepSpecifier] [':' ReductIdent] '<<' Expression '>>' [':' ReductIdent] '<:' Dimension { ',' Dimension } '>' [':' ReductIdent].
70	StepSpecifier	= '(' Expression ')' Qualident Integer .
71	ReductIdent	= AND OR Qualident .
72	ReceiveFunction	= RECEIVE ':' DirSpecifier '(' Expression ')' .
73	ReduceFunction	= REDUCE ':' ReductIdent '(' Expression ')' .
74	ArrayInitializer	= Qualident '(' ExprList ')' .
75	RecordInitializer	= Qualident '(' ExprList ')' .
76	ProcedureCall	= Designator [ActualParameters] .
77	IfStatement	= IF Expression THEN StatementSequence { ELSIF Expression THEN StatementSequence } [ELSE StatementSequence] END .
78	CaseStatement	= CASE Expression OF Case { ' ' Case } [ELSE StatementSequence] END .
79	Case	= [CaseLabelList ':' StatementSequence] .
80	WhileStatement	= WHILE Expression DO StatementSequence END .
81	RepeatStatement	= REPEAT StatementSequence UNTIL Expression .
82	ForStatement	= FOR Ident ':=' Expression TO Expression [BY ConstExpression] DO StatementSequence END .
83	LoopStatement	= LOOP [OF Qualident DO] StatementSequence END .
84	WithStatement	= WITH Designator DO StatementSequence END .
85	AllStatement	= ALL Qualident DO StatementSequence END .
86	SendStatement	= SEND ':' SendSpecifier '(' Expression ',' Designator ')' .
87	LoadStatement	= LOAD '(' Designator ',' Designator [',' Designator] ')' .
88	StoreStatement	= STORE '(' Designator ',' Designator [',' Designator] ')' .
89	Designator	= Qualident { << Expression >> <: ExprList :> ':' Ident '[' ExprList ']' '^' } .
90	Dimension	= Expression '*' '#' ReductIdent .
91	Qualident	= Ident [':' Ident] .
92	IdentList	= Ident { ',' Ident } .
93	Ident	= Letter { Letter Digit } .
94	Letter	= ('A' .. 'Z' 'a' .. 'z' '_') .
95	String	= ''' { Character } ''' '"' { Character } '"' .
96	Number	= Integer Real .
97	Integer	= Digit { Digit } ['D'] OctalDigit { OctalDigit } ('B' 'C')

	Digit { HexDigit } 'H' .
98 Real	= Digit { Digit } '.' { Digit } [ScaleFactor] .
99 ScaleFactor	= 'E' ['+' '-'] Digit { Digit } .
100 HexDigit	= Digit 'A' 'B' 'C' 'D' 'E' 'F' .
101 Digit	= OctalDigit '8' '9' .
102 OctalDigit	= '0' '1' '2' '3' '4' '5' '6' '7' .

4.5 Literature

- [Bräunl 89] T. Bräunl, *Structured SIMD Programming in Parallaxis*, Structured Programming, vol. 10, no. 3, July 1989, pp. 121-132 (12)
- [Bräunl 91] T. Bräunl, *Designing Massively Parallel Algorithms with Parallaxis*, Proceedings of the 15th Annual International Computer Software & Applications Conference, compsac91, Sep. 1991, pp. 612-617 (6)
- [Bräunl 93] T. Bräunl, *Parallel Programming – An Introduction*, Prentice Hall, Englewood Cliffs NJ, 1993
- [Bräunl, Feyrer, Rapf, Reinhardt 95] T. Bräunl, S. Feyrer, W. Rapf, M. Reinhardt, *Parallele Bildverarbeitung*, Addison-Wesley, Bonn, 1995
- [MasPar 91] MasPar Computer Corporation, *MasPar Programming Language (ANSI C compatible MPL) User Guide*, Software Version 2.2, MasPar System Documentation, DPN 9302-0101, Dec. 1991
- [Peitgen, Saupe 88] H.-O. Peitgen, D. Saupe (Eds.), *The Science of Fractal Images*, Springer-Verlag, Berlin Heidelberg New York, 1988
- [Thinking Machines 89] Thinking Machines Corporation, *Connection Machine Model CM-2 Technical Summary*, version 5.1, Technical Report, May 1989
- [Wirth 83] N. Wirth, *Programming in Modula-2*, Springer-Verlag, Berlin Heidelberg New York, 1983

PostScript-Fehler (--nostringval--, --nostringval--)